

Third Semester B.E. Degree Examination, Dec.2018/Jan.2019

Material Science

Time: 3 hrs.

Max. Marks: 100

Note: Answer any FIVE full questions, choosing ONE full question from each module.

Module-1

- 1 a. Define APF and coordination number. Calculate the APF for HCP structure. (08 Marks)
- b. Differentiate Edge dislocation and screw dislocation. (05 Marks)
- c. State and explain Fick's I and II law diffusion. (07 Marks)

OR

- 2 a. List the mechanical properties in plastic range. Explain them briefly. (08 Marks)
- b. With neat sketch, explain S-N diagram and creep curve. (12 Marks)

Module-2

- 3 a. Define solid solution. Explain the different types of solid solutions. (07 Marks)
- b. Explain the factors affecting the formation of solid solution. (05 Marks)
- c. Explain Lever rule and Gibbs phase rule with an example. (08 Marks)

OR

- 4 a. Draw Fe-Fe₃C diagram and indicate the phase temperatures and also write the invariant reaction. (12 Marks)
- b. What is homogenous nucleation? Obtain an expression for critical radius of Nuclei. (08 Marks)

Module-3

- 5 a. Draw TTT diagram for 0.8% C and super-impose the cooling curves. Explain briefly. (10 Marks)
- b. With neat sketch, explain hardening and tempering heat treatment processes. (10 Marks)

OR

- 6 a. Explain the Age hardening of Al-Cu alloys. (05 Marks)
- b. With neat sketches explain Flame Hardening. (06 Marks)
- c. List the properties and applications of Gray cast Iron, Malleable Cast Iron and S.G. Iron. (09 Marks)

Module-4

- 7 a. Define ceramics and what are its types? (06 Marks)
- b. Enumerate Electrical and Mechanical properties of ceramics. (08 Marks)
- c. Write the uses of plastics in the various field of engineering. (06 Marks)

OR

- 8 a. Differentiate the thermo plastics and thermo setting plastics. (05 Marks)
b. With a neat sketch explain the processing of plastics using injection moulding method. (10 Marks)
c. Write a note on properties and applications of smart materials. (05 Marks)

Module-5

- 9 a. Define composites. Give its classification. (05 Marks)
b. With a neat sketch, explain pultrusion process. (08 Marks)
c. What are the advantages and applications of composites? (07 Marks)

OR

- 10 a. Derive an equation for Young's modulus of FRP composites using:
i) Iso-strain condition
ii) Iso-stress condition (14 Marks)
b. Calculation the tensile modulus of elasticity of unidirectional carbon fibre reinforced composite material contains 62% by volume of carbon-fibres in
i) Iso-stress condition
ii) Iso-strain condition
Take: $E_{\text{carbon fibre}} = 37.86 \times 10^4 \text{ N/mm}^2$
 $E_{\text{epoxy}} = 42 \times 10^2 \text{ N/mm}^2$ (06 Marks)

* * * * *

CBCS SCHEME

USN

--	--	--	--	--	--	--	--	--	--

17ME33

Third Semester B.E. Degree Examination, Dec.2018/Jan.2019

Basic Thermodynamics

Time: 3 hrs.

Max. Marks: 100

Note: 1. Answer any FIVE full questions, choosing ONE full question from each module.

2. Use of Thermodynamic Data Handbook is permitted.

Module-1

- 1 a. Define the following with examples :
 - i) Open system
 - ii) Closed system
 - iii) Isolated system
 - iv) Path function
 - v) Point function.

(10 Marks)
- b. In 1709, Newton proposed a linear temperature scale where ice point and normal human body temperature are assumed as two fixed points of 0°N and 12°N respectively. The temperature of human body on the Celsius scale is 36°C. Obtain relation between Newton scale and Celsius scale. (10 Marks)

OR

- 2 a. Obtain the expression for displacement work
 - i) Isothermal process
 - ii) Polytropic process
 - iii) Isobaric process
 - iv) Isochoric process.

Draw the P-V diagram for each process. (10 Marks)
- b. Determine the total work done by a gas system following expansion process as shown below: Fig Q2(b).

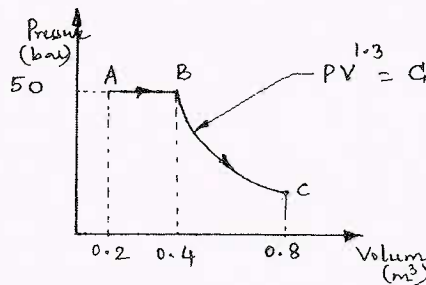

Fig Q2(b)

(10 Marks)

Module-2

- 3 a. Apply steady flow energy equation to each of following :
 - i) Boiler
 - ii) Nozzle
 - iii) Centrifugal pump
 - iv) Throttling device
 - v) Turbine. (10 Marks)
- b. A Piston and cylinder machine contains a fluid system which passes through a complete cycle of four process. During a cycle, the sum of all heat transfers is -170kJ. The system completes 100 cycles per min. Complete the following table showing the method for each item and compute the net rate of work output in kW. (10 Marks)

Process	Q (kJ/ min)	W (kJ/min)	ΔE (kJ/min)
a - b	0	2170	?
b - c	21000	0	?
c - d	-2100	?	-36600
d - a	?	?	?

Important Note : 1. On completing your answers, compulsorily draw diagonal cross lines on the remaining blank pages.
2. Any revealing of identification, appeal to evaluator and /or equations written eg. 42+8 = 50, will be treated as malpractice.

OR

- 4 a. Prove that Kelvin – Planck statement and Clausius statements of second law of thermodynamic are equivalent. (08 Marks)
 b. State Carnot's theorem. (02 Marks)
 c. A reversible heat engine operates between two reservoirs at temperature of 600°C and 40°C . The engine drives a reversible refrigerator which operates between reservoirs at temperature of 40° and -20°C . The heat transfer to the heat engine is 2000kJ and net work output of combined engine refrigerator plant is 360kJ . Evaluate the heat transfer to the refrigerant and net heat transfer to the reservoir at 40°C . (10 Marks)

Module-3

- 5 a. Explain how free expansion and friction makes the process irreversible. (08 Marks)
 b. What is internal and external irreversibility? (04 Marks)
 c. Show that entropy is a property of a system. (08 Marks)

OR

- 6 a. State and prove Clausius inequality. (10 Marks)
 b. 0.5 Kg of air initially at 27°C is heated reversibly at constant pressure until the volume is doubled and is then heated reversibly at constant volume until the pressure is doubled. For the total path, find the work transfer, heat transfer and change of entropy. (10 Marks)

Module-4

- 7 a. Explain the concept of Available and Unavailable energy. (04 Marks)
 b. Write a note on Maxwell relations. (06 Marks)
 c. A vessel of volume 0.04m^3 contains a mixture of saturated water and saturated steam at a temperature of 250°C . The mass of liquid present is 9Kg . Find the pressure, mass, specific volume, enthalpy, entropy and internal energy. (10 Marks)

OR

- 8 a. With a neat sketch, explain the working of combined separating and throttling calorimeter. (10 Marks)
 b. Steam at 0.8MPa , 250°C and flowing at the rate of 1Kg/s passes into a pipe carrying wet steam at 0.8MPa , 0.95 dry. After adiabatic mixing, the flow rate is 2.3 Kg/s . Determine the condition of steam after mixing, Neglect the velocity of steam in the pipeline. (10 Marks)

Module-5

- 9 a. State and explain i) Dalton's Law ii) Amagat's law. (08 Marks)
 b. Define the following : i) Dry bulb temperature ii) Wet bulb temperature
 iii) Specific humidity iv) Relative humidity (04 Marks)
 c. A mixture of gases has the following volumetric composition
 $\text{CO}_2 = 12\%$
 $\text{O}_2 = 4\%$
 $\text{N}_2 = 82\%$
 $\text{CO} = 2\%$
 Calculate : i) the gravimetric composition
 ii) Molecular weight of mixture
 iii) R of mixture (08 Marks)

OR

- 10 a. Derive Vander Waal's constant in terms of critical properties. (08 Marks)
 b. Explain the following : i) Compressibility factor
 ii) Law of corresponding states. (04 Marks)
 c. Determine the mass of Nitrogen contained in a 35m^3 vessel at 200 bar and 200 K by using
 i) Ideal gas equation ii) Compressibility chart. (08 Marks)

*** 2 of 2 ***

USN

--	--	--	--	--	--	--	--	--	--

17ME/MA34

Third Semester B.E. Degree Examination, Dec.2018/Jan.2019 Mechanics of Materials

Time: 3 hrs.

Max. Marks: 100

*Note: Answer any FIVE full questions, choosing
ONE full question from each module.*

Module-1

- 1 a. Derive the expression for elongation in taper round bar of length 'l', tapering uniformly for diameter 'd₁' to 'd₂' and subjected to an axial load of 'F' modulus of elasticity is E. (10 Marks)
- b. Find the elongation in a bar loaded as shown in Fig.Q.1(b). Take modulus of elasticity for steel E_S = 200GPa, for copper E_C = 100 GPa and for aluminium E_A = 70GPa. (10 Marks)

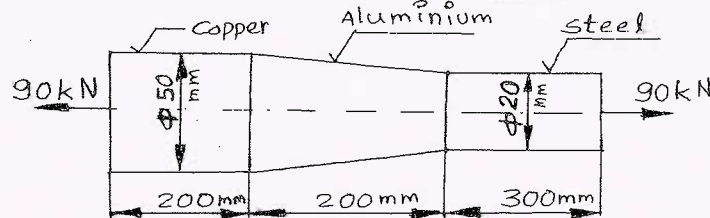

OR

- 2 a. Derive relation between Young's modulus "E" and rigidity modulus "G". (10 Marks)
- b. A steel rail 12.6m long is laid at temperature of 24°C. The maximum temperature is 44°C. Estimate the minimum gap between the rails so that the temperature stresses do not develop. Also calculate the thermal stresses developed in rails if no gap is provided between rails. If an expansion of 2mm is allowed, what is the stress induced. Take E = 200GPa, α = 12 × 10⁻⁶/°C. (10 Marks)

Module-2

- 3 a. Derive an expression for normal and shear stresses on an oblique plane inclined at 'θ' with vertical axis (x-plane) in a biaxial system subjected to stresses σ_x and σ_y on mutually perpendicular axes. (08 Marks)
- b. For an element loaded as shown in the Fig.Q.3(b), find:
 - i) Normal and shear stresses along inclined plane BE.
 - ii) Principal stresses and their angles
 - iii) Maximum shear stress and shear planes. (12 Marks)

Fig.Q.3(b)

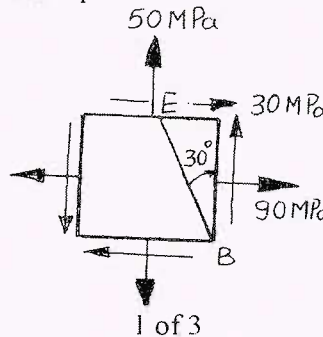

Important Note : 1. On completing your answers, compulsorily draw diagonal cross lines on the remaining blank pages.
2. Any revealing of identification, appeal to evaluator and /or equations written eg. 42+8 = 50, will be treated as malpractice.

OR

- 4 a. Derive expressions for circumferential and longitudinal stresses for a thin cylinder of diameter 'd', length 'l' and thickness 't' subjected to internal pressure 'p'. (10 Marks)
- b. A pipe of internal diameter 300mm and wall thickness of 100mm contains fluid under a pressure of 6MPa. Calculate and sketch the radial and hoop stresses induced across the wall. (10 Marks)

Module-3

- 5 Draw the shear force and bending moment diagrams for a beam loaded as shown in Fig.Q.5. Determine the location of point of contraflexure. Also find maximum bending moment and its location. (20 Marks)

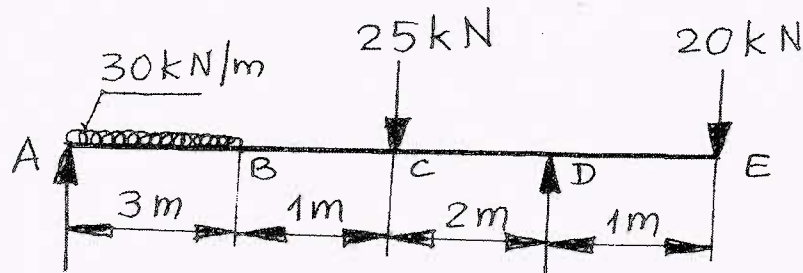

Fig.Q.5

OR

- 6 a. Derive the equation of bending $\frac{M}{I} = \frac{\sigma}{Y} = \frac{E}{R}$. (10 Marks)
- b. A simply supported beam of span 3m has T-cross section. The flange is 100mm \times 20mm and the web is 200mm \times 12mm, with the flange in compression. The maximum compressive stress is to be limited to 90MPa. Find the maximum intensity of UDL that can be carried and the corresponding tensile stress induced. (10 Marks)

Module-4

- 7 a. Derive the equation of torsion $\frac{T}{J} = \frac{\tau}{r} = \frac{G\theta}{l}$. (10 Marks)
- b. A shaft transmits 180kW at 240rpm. The allowable shear stress is 72MPa.
- Find the diameter of solid shaft.
 - Also find the diameters of hollow shaft if the inside diameter is 0.6 times its outside diameter.
 - What is the percentage of saving of material if both shafts are of same material and length? (10 Marks)

OR

- 8 a. Derive an expression for Euler's critical load for a column with both ends pinned. (10 Marks)
- b. Find the Euler's critical load for a column 1.2m long of rectangular cross section 90mm wide, 60mm depth with both ends hinged. Modulus of elasticity is 200GPa. Compare it with Rankine's critical load taking Rankine's constants $\sigma = 300$ MPa and $\alpha = \frac{1}{7500}$. (10 Marks)

Module-5

- 9 a. Derive an expression for strain energy for a member subjected to axial load. (05 Marks)
b. Explain Castigliano theorem – I (05 Marks)
c. A round rod 120mm diameter, 1.8m long transmits 300kW at 900rpm. Find the maximum strain energy stored by the rod. Take $G = 80,000 \text{ N/mm}^2$. (10 Marks)

OR

- 10 a. Define:
i) Strain energy
ii) Modulus of resilience
iii) Toughness (06 Marks)
- b. Find the diameter of round rod subjected to a bending moment of 1.8 kN-m and a torque of 1.2 kN-m, according to
i) Maximum normal stress theory
ii) Maximum shear stress theory.
Take allowable normal stress as 120MPa and allowable shear stress as 72 MPa. (14 Marks)

--	--	--	--	--	--	--	--	--	--

Third Semester B.E. Degree Examination, Dec.2018/Jan.2019 Metal Casting and Welding

Time: 3 hrs.

Max. Marks: 100

Note: Answer any FIVE full questions, choosing ONE full question from each module.

Module-1

- 1 a. Define casting process. Explain steps involved in casting process. (10 Marks)
b. What is pattern? Discuss the importance of providing various allowances to the pattern. (06 Marks)
c. Define core. Give its classification. (04 Marks)

OR

- 2 a. With a neat sketch explain the working of Jolt moulding machine. (08 Marks)
b. Explain investment moulding process with necessary sketches listing its advantages and disadvantages. (10 Marks)
c. List the functions of a Riser. (02 Marks)

Module-2

- 3 a. Explain Hot chamber pressure die casting process with a neat sketch. (08 Marks)
b. Explain continuous casting process with a neat sketch. (08 Marks)
c. Classify melting furnaces. (04 Marks)

OR

- 4 a. With a neat sketch describe the construction and working of cupola furnace. (10 Marks)
b. Describe the construction and working of Direct Arc Electric furnace with neat sketches. (10 Marks)

Module-3

- 5 a. Define solidification. List solidification variables. (04 Marks)
b. List and explain the methods of achieving directional solidification. (08 Marks)
c. Why the degasification in liquid metals is necessary? Discuss briefly the methods of removing entrapped gases in liquid metals. (08 Marks)

OR

- 6 a. Name the casting defects. Explain their causes and remedies. (08 Marks)
b. With a neat sketch explain the stir casting process. (08 Marks)
c. Mention the advantages and limitations of casting process. (04 Marks)

Module-4

- 7 a. Define welding. Classify the welding processes. (04 Marks)
b. Explain Metal-Inert-Gas (MIG) welding process with a neat diagram. (08 Marks)
c. Explain spot welding process mentioning its applications. (08 Marks)

Important Note : 1. On completing your answers, compulsorily draw diagonal cross lines on the remaining blank pages.
2. Any revealing of identification, appeal to evaluator and /or equations written eg. 42+8 = 50, will be treated as malpractice.

OR

- 8 a. Explain the thermit welding process with sketch listing its advantages and applications. (10 Marks)
- b. With a neat diagram, explain electron beam welding process. Mention its advantages, disadvantages and applications. (10 Marks)

Module-5

- 9 a. Brief about formation of different zones in welding process. (05 Marks)
- b. Define Brazing. Brief about Torch brazing process. (07 Marks)
- c. Explain Oxy-acetylene welding process with a neat sketch. (08 Marks)

OR

- 10 a. With a neat sketch explain magnetic particle inspection method and list its advantages. (10 Marks)
- b. Explain Radiography inspection method with its advantages and disadvantages. (10 Marks)

* * * * *

USN

--	--	--	--	--	--	--	--	--	--

17ME35B

Third Semester B.E. Degree Examination, Dec.2018/Jan.2019

Machine Tools and Operations

Time: 3 hrs.

Max. Marks: 100

Note: Answer any FIVE full questions, choosing one full question from each module.

Module-1

- 1 a. Define machine tool. Give classification of machine tool. (06 Marks)
- b. Classify lathes. Briefly explain various parts of lathe with neat sketch. (08 Marks)
- c. With a neat sketch, explain principal parts of sensitive drilling machine. (06 Marks)

OR

- 2 a. Define broaching. With a neat sketch explain continuous broaching machine. (07 Marks)
- b. With neat sketch explain centerless grinding machine. (07 Marks)
- c. Differentiate between up milling and down milling. (06 Marks)

Module-2

- 3 a. What is machining? With neat sketch explain relative motion of tool and work piece in grinding. (04 Marks)
- b. List the operations performed on a lathe and explain any four operations with neat sketch. (08 Marks)
- c. Explain briefly with neat sketches of any four milling machine operations. (08 Marks)

OR

- 4 a. What is indexing? Briefly explain simple indexing with an example. (08 Marks)
- b. Write short notes on following with a sketch:

i) Boring	ii) Reaming	iii) Topping
-----------	-------------	--------------

(12 Marks)

Module-3

- 5 a. What are the desirable properties of cutting tool materials? Briefly explain. (07 Marks)
- b. With a neat sketch explain geometry of single point cutting tool. (07 Marks)
- c. Define cutting fluid and explain the functions of cutting fluid. (06 Marks)

OR

- 6 a. Define surface finish. Explain the parameter affecting surface finish. (08 Marks)
- b. In a turning operation following data is observed: $D = 100$ mm, $l = 400$ mm. cutting speed $V = 500$ mm/sec, feed $f = 0.4$ mm/rev. Calculate the machining time. What will be effect on machining time if cutting speed is increased by 50%? (06 Marks)
- c. Evaluate cutting speed and machining time for the plain (slab) milling operation for the following data:

Diameter of milling cutter = 100 mm
Cutter speed = 600 rpm
Depth of cut = 5 mm
Table feed = 100 mm/min
Length of work piece = 50 cm
Number of teeth in the cutter = 8

(06 Marks)

Module-4

- 7 a. Define chip. Explain different types of chips with neat sketches. (08 Marks)
 b. Using Merchant's circle diagram, deduce the equation $F_{ns} = F_R \sin(\phi + \beta - \alpha)$. (12 Marks)

OR

- 8 a. Differentiate between Orthogonal and oblique cutting. (06 Marks)
 b. Derive an equation for shear angle $\phi' = \tan^{-1} \left(\frac{r \cos \alpha}{1 - r \sin \alpha} \right)$. (08 Marks)
 c. In orthogonal cutting of a 50 mm diameter MS bar on a lathe, the following data was obtained. Rake angle = 15° , cutting speed = 100 m/min, feed = 0.2 mm/rev, cutting force = 180 N, feed force = 60 N, chip thickness = 0.3 mm. Calculate:
 i) The shear plane angle
 ii) Coefficient of friction
 iii) Chip flow velocity
 iv) Shear force (06 Marks)

Module-5

- 9 a. Write a note on: (i) Crater wear (ii) Flank wear. (06 Marks)
 b. Explain tool wear mechanisms. (08 Marks)
 c. Define tool life. Explain parameters affecting tool life. (06 Marks)

OR

- 10 a. Write a short note on the following:
 i) Choice of feed
 ii) Choice of cutting speed
 iii) Tool life for minimum cost (12 Marks)
 b. While turning a steel rod by a given cutting tool at a given machining condition under a given environment, the tool life decreases from 80 min to 20 minutes due to increase in cutting velocity from 50 m/min to 100 m/min. At what cutting velocity the life of the same tool under the same condition and environment will be 40 minutes. (08 Marks)

* * * * *

CBCS SCHEME

USN

--	--	--	--	--	--	--	--	--	--

17ME36B

Third Semester B.E. Degree Examination, Dec.2018/Jan.2019 Mechanical Measurements and Metrology

Time: 3 hrs.

Max. Marks: 100

Note: Answer any FIVE full questions, choosing ONE full question from each module.

Module-1

- 1 a. Define Metrology. What are the objectives of metrology? (07 Marks)
b. Explain the classification of standards along with examples. (07 Marks)
c. Give brief note on System of Measurements. (06 Marks)

OR

- 2 a. Explain slip gauges in detail. What are the various methods available for the selection of slip gauges? (07 Marks)
b. What are Autocollimators? Explain with neat sketch. (07 Marks)
c. Build up a dimension of 69.2875 mm and 101.345 mm using M112 set slip gauges. (06 Marks)

Module-2

- 3 a. Explain the interchangeability and selective assembly. (10 Marks)
b. Determine the actual dimension for a hole-shaft pair designated as $28H_7/f_8$ dimensions 28 falls in the range of 18 to 30mm. Fundamental deviation for f shaft is $-5.5D^{0.41}$. IT7 = 16i and IT8 = 25i. Tolerance limit $i = 0.45D^{1/3} + 0.001D$ (Microns). (10 Marks)

OR

- 4 a. Explain Taylor's principle for the design of limit gauges. (07 Marks)
b. Briefly explain the wear allowances on gauges. (06 Marks)
c. Determine the types of fit after deciding the fundamental deviations and tolerances in the following:
Fit $\phi 70H_9 e_7$, Diameter step (50 – 80)
Fundamental deviation for e shaft = $-11 D^{0.41}$
IT7 = 16i and H₉ = 40i $i = 0.45 \sqrt[3]{D} + 0.001D$ (07 Marks)

Module-3

- 5 a. Sketch and explain Three-wire method of measuring the effective diameter of a screw thread. (08 Marks)
b. Explain with neat sketch the working of Tool maker's microscope. (07 Marks)
c. Explain Runout and Involute profile of a gear. (05 Marks)

OR

- 6 a. Explain any one laser interferometer with neat sketch and their applications. (10 Marks)
b. With a neat diagram explain the constructional and working principle of a coordinate measuring machine. (10 Marks)

Module-4

- 7 a. Explain with block diagram generalized measuring system. (08 Marks)
b. Define the following :
(i) Calibration (ii) Threshold (iii) Sensitivity (iv) System-Response and time delay (12 Marks)

OR

- 8 a. What is photoelectric transducer? Explain with neat sketch. (07 Marks)
b. With a neat schematic, explain the basic concept of Ballast circuit. (07 Marks)
c. Differentiate between oscillograph and oscilloscope. (06 Marks)

Module-5

- 9 a. Explain with neat sketch the Prony-Brake dynamometer. (10 Marks)
b. Describe the McLeod gauge with a neat sketch. (10 Marks)

OR

- 10 a. What is pyrometer? Explain the working principle of optical pyrometer. (07 Marks)
b. Explain the theory of strain gauges and define gauge factor. (05 Marks)
c. Explain thermo couple and resistance thermometer with sketches. (08 Marks)

CBCS SCHEME

USN

--	--	--	--	--	--	--	--	--	--

15ME/MA32

Third Semester B.E. Degree Examination, Dec.2018/Jan.2019 Material Science

Time: 3 hrs.

Max. Marks: 80

Note: Answer any FIVE full questions, choosing one full question from each module.

Module-1

- 1 a. Draw FCC lattice and calculate its atomic packing factor. (04 Marks)
b. Classify crystal imperfection, explain point defect in detail. (06 Marks)
c. The surface of steel gear made of 1020 steel (0.2%C) is to be gas carburized at 927°C. calculate the time required to increase the carbon content to 0.4% at 1 mm below the surface if the carbon potential at surface is 1.2 wt%. $\text{erf}(0.9) = 0.8$ (06 Marks)

OR

- 2 a. Define creep, with a typical creep curve, explain three stages of creep. (08 Marks)
b. With the help of a neat conventional stress-strain diagram, explain behavior of mild steel, under tension till fracture. (06 Marks)
c. Draw S-N curve for steel. (02 Marks)

Module-2

- 3 a. Explain Hume Rothery rules for the formation of solid solution. (06 Marks)
b. Draw and explain the Iron-Carbon equilibrium diagram and label all the points and fields. (10 Marks)

OR

- 4 a. Explain the following with example:
i) Gibb's phase rule
ii) Lever rule (10 Marks)
b. Explain any four types of stainless steel based on their crystal structure. (06 Marks)

Module-3

- 5 a. What is TTT diagram? Explain with a neat diagram the martensitic transformation of austenite. (08 Marks)
b. Write notes on the following:
i) Annealing
ii) Carburizing (08 Marks)

OR

- 6 a. What is hardening? Explain with a neat sketch induction hardening. (08 Marks)
b. Briefly explain the composition, properties and applications of grey cast iron. (08 Marks)

Module-4

- 7 a. What are properties of ceramic materials? (04 Marks)
b. With a neat sketch, explain tape casting. (06 Marks)
c. Explain with a neat diagram, the processing of plastic by injection molding. (06 Marks)

Important Note : 1. On completing your answers, compulsorily draw diagonal cross lines on the remaining blank pages.
2. Any revealing of identification, appeal to evaluator and /or equations written eg. 42+8 = 50, will be treated as malpractice.

OR

- 8 a. Explain working principle of optical fiber. (06 Marks)
b. What are the applications of shape memory alloys? (06 Marks)
c. Explain any two methods of NDT. (04 Marks)

Module-5

- 9 a. With a neat sketch, explain filaments winding. (08 Marks)
b. Explain production of composite materials by spray-up process. (08 Marks)

OR

- 10 a. A tensile load of 500 N is applied to a epoxy-glass fiber composite. If the cross section of the composite is 1 mm^2 and the volume of the fiber is 30% calculate the stress in the glass fiber when:
i) The load axis is parallel to the fiber
ii) The load axis is perpendicular to the fiber.
Take the values of Young's modulus for the glass fiber as 86 GN/m^2 and for matrix as 3.38 GN/m^2 . (06 Marks)
- b. Explain the following:
i) Production of MMC's by stir casting
ii) Pultrusion process. (10 Marks)

* * * * *

CBCS SCHEME

USN

--	--	--	--	--	--	--	--	--	--

15ME33

Third Semester B.E. Degree Examination, Dec.2018/Jan.2019 Basic Thermodynamics

Time: 3 hrs.

Max. Marks: 80

- Note:** 1. Answer any FIVE full questions, choosing one full question from each module.
2. Use of Thermodynamic data hand book is permitted.

Module-1

- 1 a. Explain Microscopic and Macroscopic approaches to thermodynamics. (06 Marks)
b. State and explain zeroth law of thermodynamic. (04 Marks)
c. The temperature T on a thermometric scale is defined as $T = a \ln K + b$ where a and b are constants. The values of K are found to be 1.83 and 6.78 at 0°C and 100°C respectively. Calculate the temperature for value of $K = 2.42$. (06 Marks)

OR

- 2 a. Obtain an expression for displacement adiabatic work (work done in an adiabatic process). (06 Marks)
b. Define heat and work with reference to thermodynamic point of view. (04 Marks)
c. A gas expands from an initial state where the pressure is 340KPa and the volume is 0.0425 m^3 to a final pressure of 136KPa. The relationship between the pressure and volume of the gas is $PV^2 = \text{constant}$. Determine the work done for this process. (06 Marks)

Module-2

- 3 a. Derive the steady flow energy equation for an open system. (04 Marks)
b. Show that the Kelvin – Planck and Clausius's statement of the II law of thermodynamic are equivalent. (06 Marks)
c. A gaseous system undergoes three quasistatic processes in sequence. The gas initially at 5 bar 0.01 m^3 is expanded at constant pressure. It is then further expanded according to the relation $PV^{1.4} = C$ to 2 bar, 0.025 m^3 . The gas is then returned to the initial state during which process $PV = \text{constant}$ calculate the work interaction in each of three process and the net work for the system. (06 Marks)

OR

- 4 a. Obtain a relation between COP's of a refrigerator and heat pump. (06 Marks)
b. State and explain the ideal Carnot cycle on P-V diagram. (04 Marks)
c. A series combination of two Carnot engines operates between the temperature of 180°C and 20°C . Calculate the intermediate temperature, if the engine produce equal amounts of work. (06 Marks)

Module-3

- 5 a. Explain the factors that render a process irreversible. (06 Marks)
b. Explain internal and external irreversibility with equation. (04 Marks)
c. A reversible engine operates between a source at 927°C and two sinks at 127°C and 27°C . The energy rejected at both the sinks is the same compute the engine efficiency. (06 Marks)

Important Note : 1. On completing your answers, compulsorily draw diagonal cross lines on the remaining blank pages.
2. Any revealing of identification, appeal to evaluator and /or equations written eg. 42+8 = 50, will be treated as malpractice.

OR

- 6 a. State and prove Clausius inequality and hence define entropy. (06 Marks)
 b. Plot and explain the Carnot cycle with help of temperature entropy diagram. (04 Marks)
 c. A 10kg bar of cast iron initially at 400°C is quenched in a 20 litres water tank initially at 25°C. Assuming no heat transfer with the surroundings and no boiling away of liquid water calculate the net entropy change for the process. $C_{p\text{castiron}} = 0.5$, $C_{p\text{water}} = 4.187$ kJ/kg K. (06 Marks)

Module-4

- 7 a. Obtain an expression for maximum useful work for a system and control volume. (06 Marks)
 b. Define Gibb's and Helmholtz functions and explain its significances. (04 Marks)
 c. Exhaust gases leave an I.C engine at 750°C and 1 atm, after having done 450kJ per kg gas in the engine cylinder. Assume that the enthalpy of the gas is a function of temperature only and that $C_p = 1.1$ kJ/kg K. Assume the temperature of the surrounding to be 27°C. Calculate :
 i) The available and unavailable parts of the energy in every kg gas discharged
 ii) The ratio of available energy to start to the engine work. (06 Marks)

OR

- 8 a. Sketch and explain Throttling Calorimeter. (08 Marks)
 b. Define the following terms : i) Dryness fraction ii) Latent heat
 iii) Total heat of wet steam iv) Superheated steam. (04 Marks)
 c. Find the specific volume, enthalpy and internal energy of wet steam at 18 bar pressure and dryness fraction of 0.85. (04 Marks)

Module-5

- 9 a. Explain Dalton's law of partial pressure and Amagat's law of additive volumes with reference to ideal gas mixture. (06 Marks)
 b. Derive an expression for internal energy and enthalpy of gaseous mixtures. (04 Marks)
 c. A mixture of gases contains 1kg of CO₂ and 1.5kg of N₂. The pressure and temperature of the mixture are 3.5bar and 27°C. Determine for the mixture.
 i) The mass and mole traction of each constituent gas
 ii) Average molecular weight
 iii) The partial pressures. (06 Marks)

OR

- 10 a. Explain the following :
 i) Generalized compressibility chart
 ii) Law of corresponding states
 iii) Compressibility factor (06 Marks)
 b. Derive Vander Waal's constants interms of critical properties. (06 Marks)
 c. Determine the pressure exerted by CO₂ in a container of 1.5m³ capacities when it contains 5kg at 27°C.
 i) Using ideal gas equations
 ii) Using Vander Waal's equation. (04 Marks)

* * * * *

CBCS SCHEME

USN

--	--	--	--	--	--	--	--	--	--

15ME/MA34

Third Semester B.E. Degree Examination, Dec.2018/Jan.2019

Mechanics of Materials

Time: 3 hrs.

Max. Marks: 80

Note: Answer any FIVE full questions, choosing ONE full question from each module.

Module-1

- 1 a. Draw the stress-strain diagram of a M-S specimen subjected to tension test and explain the salient points. (06 Marks)
- b. Determine the magnitude of the load P necessary to produce zero net change in the length of a straight bar shown in Fig.Q1(b). Area A = 400 mm².

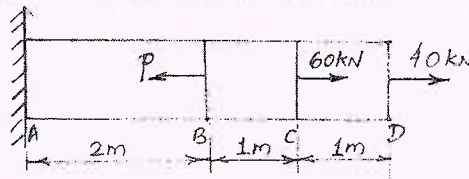

(10 Marks)

OR

- 2 a. Define Poisson's ratio. Derive an expression for volumetric strain of a rectangular bar subjected to normal stress along the three axis. (08 Marks)
- b. A composite bar is rigidly fitted at the supports A and B as shown in Fig.Q2(b). Determine the reactions at the supports when temperature rises by 20°. Take $E_A = 70$ GPa, $E_S = 200$ GPa, $\alpha_A = 11 \times 10^{-6}/^\circ\text{C}$ and $\alpha_S = 12 \times 10^{-6}/^\circ\text{C}$.

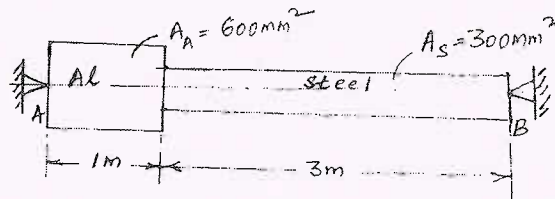

(08 Marks)

Module-2

- 3 a. Derive an expression for the normal stress and shear stress on a plane inclined at θ to the vertical axis in a biaxial stress system. (06 Marks)
- b. At a point in a strained material, the stresses on two planes at right angles to each other are 80 N/mm² (tensile) and 40 N/mm² (tensile). Each of the above stresses are accompanied by a shear stress of 60 N/mm². Determine normal stress, shear stress and resultant stress on an inclined plane (oblique plane) at an angle of 45° to the axis of minor tensile stress. Also find major principal stress, minor principal stress and their location. (10 Marks)

OR

- 4 a. Derive an expression for circumferential and longitudinal stress in a thin cylinder subjected to internal pressure p. (06 Marks)
- b. A thick cylindrical pipe of outside diameter 300 mm and internal diameter 200 mm is subjected to an internal fluid pressure of 20 N/mm² and external fluid pressure of 5 N/mm². Determine the maximum Hoop stress developed. Draw the variation of Hoop stress and radial stress across the thickness of the pipe indicating the values at every 25 mm interval. (10 Marks)

(10 Marks)

Important Note : 1. On completing your answers, compulsorily draw diagonal cross lines on the remaining blank pages.
2. Any revealing of identification, appeal to evaluator and/or equations written eg. 42+8 = 50, will be treated as malpractice.

Module-3

- 5 a. Derive an expression to establish a relationship between intensity of load, shear force and bending moment. (06 Marks)
- b. Draw the shear force and bending moment diagram for the beam loaded as shown in Fig.Q5(b). Locate the point of contraflexure if any.

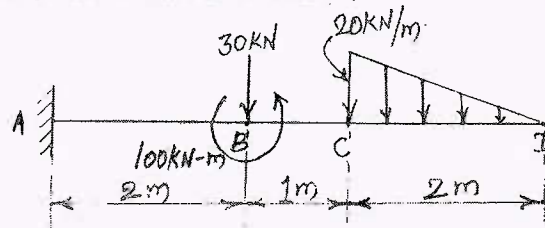

Fig.Q5(b)

(10 Marks)

OR

- 6 a. A simply supported beam of 'I' section carries a uniformly distributed load of 40 kN/m run on entire span of beam of 10 m. If 'I' section is having dimensions as shown in Fig.Q6(a), determine the maximum stress developed due to bending.

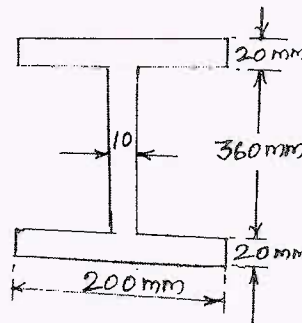

Fig.Q6(a)

(08 Marks)

- b. Find the deflection at the free end of cantilever beam shown in Fig.Q6(b). Take $E = 2 \times 10^5 \text{ N/mm}^2$, $I = 180 \times 10^6 \text{ mm}^4$.

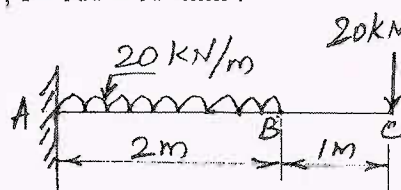

Fig.Q6(b)

(08 Marks)

Module-4

- 7 a. Derive the torsion equation $\frac{T}{J} = \frac{\tau}{R} = \frac{G\theta}{L}$ with usual notations. (08 Marks)
- b. A hollow circular shaft has to transmit 60 kW at 210 rpm such that the maximum shear stress does not exceed 60 MN/m^2 . If the ratio of internal to external diameter is equal to $\frac{3}{4}$ and the value of rigidity modulus is 84 GPa, find the dimensions of the shaft and angle of twist in a length of 3m. (08 Marks)

OR

- 8 a. Derive Euler's equation of a column with one end fixed and other end free. (06 Marks)
- b. A 1.5 m long column has a circular cross-section of 50 mm diameter. One end of the column is fixed and the other end is free. Taking factor of safety as 3, calculate the safe load using:
- Rankine's formula, taking yield stress 560 N/mm^2 and $\alpha = \frac{1}{1600}$.
 - Euler's formula, taking $E = 1.2 \times 10^5 \text{ N/mm}^2$. (10 Marks)

Module-5

- 9 a. State and explain three main theories of failure applicable to complex stress system. (06 Marks)
- b. A bolt is acted upon by an axial pull of 16 kN along with a transverse shear force of 10 kN. Determine the diameter of the bolt required, using
- Max. principal stress theory
 - Max. shear stress theory
 - Max. strain theory
- Elastic limit in tension = 250 MPa
Factor of safety = 2.5
Poisson's ratio = 0.3 (10 Marks)

OR

- 10 a. Write a note on:
- Castigliano's I theorem
 - Strain energy due to bending and torsion. (06 Marks)
- b. The maximum stress produced by a pull in a bar of length 1100 mm is 100 N/mm^2 . The area of cross sections of length are shown in Fig.Q10(b). Calculate the strain energy stored in the bar if $E = 2 \times 10^5 \text{ N/mm}^2$.

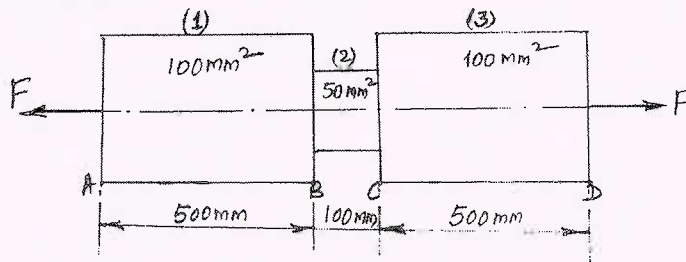

Fig.Q10(b)

(10 Marks)

--	--	--	--	--	--	--	--	--	--

Third Semester B.E. Degree Examination, Dec.2018/Jan.2019

Metal Casting and Welding

Time: 3 hrs.

Max. Marks: 80

Note: Answer any FIVE full questions, choosing one full question from each module.

Module-1

- 1 a. Name the factors that determine the selection of a casting alloy. (04 Marks)
b. Explain various pattern allowances. (08 Marks)
c. What are the requirements of base sand? (04 Marks)

OR

- 2 a. Explain the working of a sand slinger with a neat sketch. (08 Marks)
b. Explain with neat figures, shell moulding technique. (08 Marks)

Module-2

- 3 a. Explain with a diagram the working of electrical arc furnace. (08 Marks)
b. Explain with a neat figure, the principle of working of resistance furnace. (08 Marks)

OR

- 4 a. Explain continuous casting process with a neat sketch. (08 Marks)
b. Explain squeeze casting process with diagrams. (08 Marks)

Module-3

- 5 a. Name the solidification variables and explain them briefly. (06 Marks)
b. List the advantages and limitations of casting process. (06 Marks)
c. What is meant by grain refining and pouring temperature of aluminium castings? (04 Marks)

OR

- 6 a. Explain various degasification methods in liquid metals. (08 Marks)
b. Enlist the advantages and limitations of aluminium castings. (04 Marks)
c. Explain the reasons for fluxing and flushing of aluminium castings. (04 Marks)

Module-4

- 7 a. Define welding. Enumerate the advantages and limitations of welding. (05 Marks)
b. Describe the working of submerged arc welding with a neat diagram. (05 Marks)
c. Explain the principle of operation of seam welding process with a neat sketch. (06 Marks)

OR

- 8 a. Explain the flux shielding metal arc welding with a sketch. (08 Marks)
b. Explain the principle of spot welding with a neat sketch. (08 Marks)

Module-5

- 9 a. Explain the formation of different zones in weld with a neat sketch. (08 Marks)
b. Define soldering. Explain the mechanism of soldering. (04 Marks)
c. Differentiate between soldering and brazing. (04 Marks)

OR

- 10 a. Explain the principle of Oxy-acetylene welding. (03 Marks)
b. Explain the types of flames in oxy-acetylene welding with sketches. (06 Marks)
c. Briefly explain non-destructive testing method in welding. Mention its advantages limitations. (07 Marks)

* * * * *

Important Note : 1. On completing your answers, compulsorily draw diagonal cross lines on the remaining blank pages.
2. Any revealing of identification, appeal to evaluator and /or equations written eg. 42+8 = 50, will be treated as malpractice.

USN

--	--	--	--	--	--	--	--	--	--

15MEB306

Third Semester B.E. Degree Examination, Dec.2018/Jan.2019 Mechanical Measurements and Metrology

Time: 3 hrs.

Max. Marks: 80

Note: Answer FIVE full questions, choosing one full question from each module.

Module-1

- 1 a. Describe the type of errors encountered during the measurement process. (08 Marks)
 b. Three 100 mm end bars are measured on a level comparator by first wringing them together and comparing with 300 mm bar which itself has +0.03 mm error. Three bars together have total error of 0.064 mm less than the standard bar. Bar A is 0.02 mm larger than bar B and 0.025 mm longer than bar C. Determine the actual dimensions of all end bars. (08 Marks)

OR

- 2 a. With a neat sketch, explain the use of Auto collimator to measure squareness of surfaces. (08 Marks)
 b. Mention the availability of flip gauges in M112 set. Using M112 set slip gauges build dimensions (i) 52.498 mm (ii) 48.3275 mm. (08 Marks)

Module-2

- 3 a. With a common zero line, indicate and define the following terms for shaft and hole (i) Basic size (ii) Allowance (iii) Upper deviation (iv) Lower deviation. (08 Marks)
 b. Determine the actual dimensions to be provided for a shaft and hole of 90 mm size for H₈C₉ type fit. IT₈ = 25 i, IT₉ = 40i. FD for 'e' shaft = -11D^{0.41} (08 Marks)

OR

- 4 a. Explain the construction and working of LVDT. (08 Marks)
 b. Explain the construction and working of Zeiss ultra optometer. (08 Marks)

Module-3

- 5 a. What is best wire size? Derive an expression for best wire diameter in terms of pitch and thread angle. (08 Marks)
 b. Describe the use of David Brown tangent comparator for gear measurement. Calculate the dimension of the base tangent length over 3 teeth with module of 2.5 mm, 20° pressure angle and 30 teeth. (08 Marks)

OR

- 6 a. Explain the construction and working of laser interferometer. (08 Marks)
 b. Describe the working of cantilever type CMM. (08 Marks)

Module-4

- 7 a. Describe (i) Accuracy (ii) Precision (iii) Calibration (iv) Threshold (08 Marks)
 b. Explain the pressure sensitive elements used as mechanical transducers. (08 Marks)

OR

- 8 a. Explain the inherent problems in mechanical systems. (08 Marks)
 b. Describe the working of stylus type oscillograph. (08 Marks)

Module-5

- 9 a. Describe the construction and working of proving ring. (08 Marks)
 b. Describe the construction and working of prony brake. (08 Marks)

OR

- 10 a. Describe the construction and working of strain gauge load cell. (08 Marks)
 b. What is thermocouple? Explain the laws of thermocouple. (08 Marks)

* * * * *

Important Note : 1. On completing your answers, compulsorily draw diagonal cross lines on the remaining blank pages.
 2. Any revealing of identification, appeal to evaluator and /or equations written eg, 42+8 = 50, will be treated as malpractice.

CBCS SCHEME

USN

--	--	--	--	--	--	--	--	--	--

17ME32

Third Semester B.E. Degree Examination, June/July 2019

Material Science

Time: 3 hrs.

Max. Marks: 100

Note: Answer any FIVE full questions, choosing ONE full question from each module.

Module-1

- 1 a. Define Atomic Packing Factor and calculate Atomic Packing Factor for FCC Crystal Structure. (08 Marks)
- b. State and explain Ficks first law of Diffusion. (06 Marks)
- c. Explain the different types of Point Imperfections, with neat sketches. (06 Marks)

OR

- 2 a. Draw Stress – Strain diagram for mild steel and cast iron. Explain its behaviour under uniaxial Tension until fracture. (08 Marks)
- b. What is Fracture? How are they classified? (04 Marks)
- c. With a neat sketch, explain the different stages of creep deformation. (08 Marks)

Module-2

- 3 a. With a neat sketch, explain the construction of phase diagram. (08 Marks)
- b. Explain Gibbs phase rule and Lever rule. (06 Marks)
- c. With a neat sketch, explain different cast metal structures. (06 Marks)

OR

- 4 a. Explain Homogeneous nucleation and discuss the significance of critical radius of nuclei. (10 Marks)
- b. Two metals A & B of melting points 900°C and 700°C respectively have unlimited mutual liquid solubilities. The solid solubility of B in A is 30% at eutectic temperature of 400°C , which reduces to 20% at 0°C . The solid solubility of A in B is 20% at eutectic temperature which reduces to 15% at 0°C . The eutectic composition is 70%B and 30% A. Draw the phase diagram. Calculate the solid and liquid phases of 40% B alloy at 500°C . (10 Marks)

Module-3

- 5 a. Draw TTT diagram for eutectoid steel (0.83% C) and explain different micro structures. (08 Marks)
- b. Sketch and explain Austempering and Martempering. (08 Marks)
- c. Sketch and explain Flame hardening. (04 Marks)

OR

- 6 a. Define and list the types of Heat Treatment processes. (05 Marks)
- b. With a neat sketch, explain Jomine End Queuch test. (08 Marks)
- c. Sketch and explain Nitriding process. (07 Marks)

Module-4

- 7 a. Define Ceramics and briefly explain the types of ceramics. (08 Marks)
- b. Explain Powder Metallurgy technique for Ceramic processing. (08 Marks)
- c. Differentiate between Thermoplastics and Thermoset plastics. (04 Marks)

1 of 2

Important Note : 1. On completing your answers, compulsorily draw diagonal cross lines on the remaining blank pages.
2. Any revealing of identification, appeal to evaluator and /or equations written eg, $42+8=50$, will be treated as malpractice.

OR

- 8 a. Briefly explain the characteristics of plastics. (05 Marks)
b. Define Smart Materials. Write a note on PieZoelectric materials. (05 Marks)
c. Write a note on Shape Memory alloys. List the Applications of Smart Materials. (10 Marks)

Module-5

- 9 a. Define Composites and classify them. (05 Marks)
b. Sketch and explain Filament winding process to produce composites. (08 Marks)
c. Write a note on Fibre reinforced plastic composites. (07 Marks)

OR

- 10 a. Derive an expression for Young's Modulus in a composite for longitudinal loading of fibre reinforced composite. (08 Marks)
b. Calculate the volume ratio of Aluminum and Boron in Aluminum – Boron composite having Young's Modulus equal to Iron. The Young's Moduli of Aluminum, Boron and Iron are respectively 71 GPa, 440 GPa and 210 GPa. (08 Marks)
c. State some Applications of composites. (04 Marks)

* * * * *

Third Semester B.E. Degree Examination, June/July 2019 Basic Thermodynamics

Time: 3 hrs.

Max. Marks: 100

*Note: 1. Answer any FIVE full questions, choosing
ONE full question from each module.*

2. Use of Thermodynamics data hand book permitted.

Module-1

- 1 a. With examples briefly describe the terms:
- i) Macroscopic approach
 - ii) Intensive properties
 - iii) Closed systems
 - iv) Quasistatic process. (08 Marks)
- b. Define Zeroth law of thermodynamics and explain the concept of temperature measurement. (04 Marks)
- c. A platinum wire is used as resistance thermometer. The wire resistance was found to be 10Ω and 16Ω at ice and steam points respectively and 30Ω at sulphur boiling point 444.6°C . Find the constants a and b in the equation $R = R_0 (1 + at + bt^2)$ where t in $^\circ\text{C}$. Also find the resistance of the wire at 500°C . (08 Marks)

OR

- 2 a. Describe the similarities and dissimilarities between work and heat transfer. (06 Marks)
- b. With the help of p - v diagrams, derive expressions for p - dv work for i) isothermal process
ii) Polytropic process. (06 Marks)
- c. A gas is initially at 100kPa and 6000 cm^3 . The final volume is 2000 cm^3 . Determine the moving boundary work for each of the following processes:
- i) When P is proportional to V
 - ii) When P is inversely proportional to V
 - iii) $PV^2 = \text{constant}$. (08 Marks)

Module-2

- 3 a. With a neat sketch, explain Joule's experiment and hence define first law of thermodynamics. (06 Marks)
- b. Briefly describe internal energy as a property of the system. (04 Marks)
- c. Write SFEE and explain the terms. (02 Marks)
- d. A steam nozzle is supplied with 40kg/min of steam at 15 bar . At the inlet $V_1 = 1800\text{m/min}$ and $v_1 = 0.15\text{ m}^3/\text{kg}$, $u_1 = 2600\text{ kJ/kg}$ and corresponding values at the exit are $p_2 = 1\text{ bar}$, $v_2 = 1.7\text{m}^3/\text{kg}$ and $u_2 = 2520\text{ kJ/kg}$. Calculate the exit velocity. (08 Marks)

OR

- 4 a. Briefly explain the terms:
- i) Thermal reservoir
 - ii) Refrigerator
 - iii) Heat pump
 - iv) Clausius statement of II law. (08 Marks)

- b. With the help of p-v diagram, derive an expression for the efficiency of a Carnot cycle. (06 Marks)
- c. A reversible engine with 40% efficiency discharges 1520 kJ of heat per minute at 27°C to a pond. Find the temperature of the source which supplies the heat to the engine and power developed by the engine. (06 Marks)

Module-3

- 5 a. Define the terms:
 i) Reversible process
 ii) Reversible heat engine
 iii) Irreversible process. (06 Marks)
- b. Describe with a sketch heat transfer through a finite temperature difference is irreversible. (06 Marks)
- c. A reversible heat engine operates between two reservoirs at temperatures of 600°C and 40°C. The engine drives a reversible refrigerator which operates between reservoirs at temperatures of 40°C and -20°C. The heat transfer to the engine is 2000kJ and the network output of the engine refrigerator plant is 360kJ. Evaluate the heat transfer to the refrigerant and net heat transfer to the reservoir at 40°C. (08 Marks)

OR

- 6 a. With p-v diagram explain Clausius inequality. (06 Marks)
- b. Explain the principle of increase of entropy. (04 Marks)
- c. Show that entropy is the property of a system. (04 Marks)
- d. 10 gram of water at 20°C is converted into ice at -10°C in a constant pressure process of 1 atmosphere. Calculate the change in entropy for the process. Take $c_{p_{water}} = 4.187 \text{ kJ/kg K}$, $c_{p_{ice}} = 2.093 \text{ kJ/kg K}$, LH of ice = 335 kJ/kg. (06 Marks)

Module-4

- 7 a. Represent available and unavailable energy as referred to a cycle with T-S diagrams. (06 Marks)
- b. Explain the concept of second law efficiency. (06 Marks)
- c. Calculate the decrease in available energy when 25kg of water at 95°C mix with 35kg of water at 35°C at constant pressure and the temperature of the surroundings being 15°C (Take $c_{pw} = 4.2 \text{ kJ/kgK}$). (08 Marks)

OR

- 8 a. Explain the terms:
 i) Triple point
 ii) Critical point
 iii) Sub cooled liquid
 iv) Quality of steam. (06 Marks)
- b. With a neat sketch and h-s diagram explain throttling calorimeter. (06 Marks)
- c. A vessel of volume 0.04m^3 contains a mixture of saturated water and saturated steam at a temperature of 250°C. The mass of the liquid present is 9kg. Find the pressure, mass, specific volume, enthalpy, entropy and internal energy. (08 Marks)

Module-5

- 9 a. Define:
- i) Dalton's law of partial pressure. (06 Marks)
 - ii) Amagat's law of additive volume (04 Marks)
 - iii) Ideal gas
- b. Derive an expression for the change in entropy of an ideal gas. (04 Marks)
- c. A gaseous mixture consists of 1kg of oxygen and 2kg of nitrogen at a pressure of 150kPa and a temperature of 20°C. Find:
- i) Gas constant
 - ii) Molecular weight of the mixture
 - iii) Mole Fractions
 - iv) Partial pressures
 - v) Specific heats of the mixture. (10 Marks)

OR

- 10 a. Define:
- i) Law of corresponding states (06 Marks)
 - ii) Compressibility factor
 - iii) Real Gas.
- b. Write Vander Waal's equation of state and express the constants in terms of critical properties. (06 Marks)
- c. The specific volume of CO₂ is 1m³/kg at 100°C. Determine the pressure exerted by CO₂ using Vander Waal's equation and compare the results obtained if CO₂ is treated as an ideal gas. (08 Marks)

CBCS SCHEME

USN

--	--	--	--	--	--	--	--	--	--

17
17ME35A

Third Semester B.E. Degree Examination, June/July 2019 Metal Casting and Welding

Time: 3 hrs.

Max. Marks: 100

*Note: Answer any FIVE full questions, choosing
ONE full question from each module.*

Module-1

- 1 a. Explain briefly the basic steps involved in sand casting process. (04 Marks)
b. Define Pattern. List the pattern materials and explain any 2 pattern materials. (08 Marks)
c. Discuss the characteristics of molding sand. (08 Marks)

OR

- 2 a. With a suitable sketch, explain the following terms:
i) Sprue ii) Pouring basin iii) Runner iv) Ingates v) Riser. (10 Marks)
b. With a neat diagram briefly explain investment casting. (10 Marks)

Module-2

- 3 a. Briefly explain hot chamber pressure die-casting with a neat sketch. (10 Marks)
b. Draw coreless induction furnace and explain in brief state the advantages. (10 Marks)

OR

- 4 a. With a neat diagram, explain various zones in cupola furnace. Write the reactions taking places in each zone. (10 Marks)
b. Draw and explain the following: i) Continuous casting ii) Centrifugal casting. (10 Marks)

Module-3

- 5 a. Define the following terms:
i) Growth and Nucleation in solidification. (08 Marks)
ii) Homogeneous and Heterogeneous nucleation. (08 Marks)
b. Briefly explain directional solidification and progressive solidification with neat sketch. (08 Marks)
c. Define solidification. Explain the concept of solidification in casting. (04 Marks)

OR

- 6 a. Define degasification. Classify degasification process. Explain any 2 methods of degasification. (10 Marks)
b. List the casting defects. Discuss various methods to reduce the defects. (10 Marks)

Module-4

- 7 a. With a neat sketch explain TIG welding and state advantages and disadvantages of TIG welding. (10 Marks)
b. Describe Atomic Hydrogen Welding (AHW) briefly with a neat diagram. (10 Marks)

Important Note: 1. On completing your answers, compulsorily draw diagonal cross lines on the remaining blank pages.
2. Any revealing of identification, appeal to evaluator and /or equations written eg, 42+8 = 50, will be treated as malpractice.

OR

- 8 a. With a neat sketch describe thermit welding and state the advantages. (10 Marks)
b. Explain briefly with a neat sketch Laser Beam welding. State the application. (10 Marks)

Module-5

- 9 a. Describe Heat Effected Zone (HAZ). Discuss the parameters affecting HAZ. (10 Marks)
b. List welding defects. Explain any 5 defects with its cause and remedies. (10 Marks)

OR

- 10 a. With neat sketch explain magnetic particle inspection and florescent particle inspection. (10 Marks)
b. Draw and explain different types of flames in oxy-acetylene welding process. (10 Marks)

* * * * *

CBCS SCHEME

USN

--	--	--	--	--	--	--	--	--	--

17ME35B

Third Semester B.E. Degree Examination, June/July 2019

Machine Tools and Operations

Time: 3 hrs.

Max. Marks: 100

Note: Answer any FIVE full questions, choosing ONE full question from each module.

Module-1

- 1 a. Write the classification of machine tools. (05 Marks)
b. Define: i) Drilling ii) Milling iii) Turning iv) Grinding v) Broaching. (05 Marks)
c. Explain the constructional features of planning machine with a neat sketch. (10 Marks)

OR

- 2 a. List and classify different types of drilling machines. (05 Marks)
b. With a suitable sketch, explain the size and specifications of engine lathe. (05 Marks)
c. With a neat sketch, explain constructional features of centreless grinding machine. (10 Marks)

Module-2

- 3 a. Define primary and secondary motions in machining. (04 Marks)
b. With sketches, differentiate between up milling and down milling operations. (06 Marks)
c. Define the machining parameters: i) Cutting-speed ii) Feed iii) Depth of cut iv) Machining time v) Metal removal rate with respect to shaping operation. (10 Marks)

OR

- 4 a. With sketches, differentiate between shaping and planing operations. (07 Marks)
b. With suitable sketches, explain cylindrical traverse grinding and plunge cylindrical grinding. (06 Marks)
c. What is slab milling, and explain the determination of machining time for slab milling operation. (07 Marks)

Module-3

- 5 a. List various cutting tool materials in the increasing order of their hardness. (05 Marks)
b. Mention the effects of adding following alloying elements in High Speed Steel (H.S.S) tool material (Also mention approximate percentage of each element.
i) Tungsten ii) Molybdenum iii) Vanadium iv) Cobalt. (07 Marks)
c. Show the different cutting angles of a single point cutting tool, with a neat sketch. (08 Marks)

OR

- 6 a. List the desirable properties of cutting fluids, recommend suitable cutting fluid to machine
i) Aluminium ii) Copper and copper alloys iii) Cast iron. (08 Marks)
b. Define: i) Roughness ii) Waviness iii) Lay iv) Surface flaws with respect to surface finish. (04 Marks)
c. A work piece of diameter 38mm and length 400mm was turned on a Lathe using a suitable cutting tool. Determine the machining time to reduce the work piece to 36.5mm diameter in one pass with cutting speed of 30mpm and feed 0.7mm / revelation. (08 Marks)

Important Note : 1. On completing your answers, compulsorily draw diagonal cross lines on the remaining blank pages.
2. Any revealing of identification, appeal to evaluator and /or equations written eg. 42+8 = 50, will be treated as malpractice.

Module-4

- 7 a. With a suitable sketch, describe orthogonal and oblique cutting operations. (10 Marks)
 b. Derive the condition $2\phi + \beta - \alpha = \pi/2$ for orthogonal cutting. Explain its significance with usual notations. (10 Marks)

OR

- 8 a. What types of chips are generated while machining i) Cast iron ii) Mild steel iii) Copper. Justify your answer. (06 Marks)
 b. Explain the relationship between cutting velocity and chip flow velocity and cutting velocity and shear velocity and prove the same. (06 Marks)
 c. In an experiment a pipe is turned on end in orthogonal cutting condition with a tool of 20° rake angle. A chip length of 85mm is obtained from an uncut chip length of 202mm while cutting with a depth of cut of 0.5mm. Determine the shear plane angle and chip thickness. (08 Marks)

Module-5

- 9 a. Define tool wear. Explain the following terms:
 i) Diffusion wear mechanism
 ii) Fatigue wear mechanism. (06 Marks)
 b. Explain the factors affecting the machinability of a material. (06 Marks)
 c. If $n = 0.4$ and $c = 400$ in the Taylor's tool life equation for tool wear. What is the percentage increase in tool life if the cutting speed is reduced by 20%? (08 Marks)

OR

- 10 a. Explain graphically the variation of components of machining cost with cutting speed. (10 Marks)
 b. The following Taylor tool life equation for carbide tool steel work piece pair was obtained experimentally $VT^{0.25} = 650$. Where 'V' is in m/min and 'T' in min. A batch of 1000 steel parts each 100mm in diameter and 250mm in length is to be rough turned using a feed of 0.2mm/revolⁿ. If the cost per cutting edge of the throw away carbide insert is Rs.50, time required to reset the cutting edge is 1 min and the total machine rate is Rs.300/hr, calculate:
 i) Optimum cutting speed for minimum cost ii) Corresponding tool life. (10 Marks)

* * * * *

USN

2	V	D	I	G	M	E	O	G	2
---	---	---	---	---	---	---	---	---	---

17ME/MA34

Third Semester B.E. Degree Examination, June/July 2019 Mechanics of Materials

Time: 3 hrs.

Max. Marks: 100

Note: Answer any FIVE full questions, choosing ONE full question from each module.

Module-1

1. a. State the Hooke's Law. Neatly draw the stress – strain diagram for steel indicating all salient points and zones on it. (05 Marks)
- b. Derive an expression for the extension of uniformly tapering circular bar subjected to axial load. (05 Marks)
- c. A steel bar ABCD of varying sections is subjected to the axial forces as shown in fig.Q1(c). Find the value of P necessary for equilibrium. If $E = 210 \text{ kN/mm}^2$, determine
 - i) Stress in various segments
 - ii) Total elongation of bar. (10 Marks)

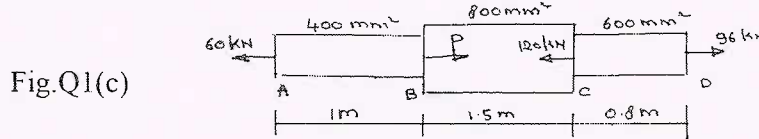

OR

2. a. A compound bar is made up of a central aluminium plate 24mm wide and 6mm thick to which steel plates of 24mm wide and 9mm thick are connected rigidly on each side. The length of compound bar at temperature 20°C is 100mm. If the temperature of the whole assembly is raised by 60°C , determine the stress in each of the material. If at the new temperature a compressive load of 20kN is applied to the composite bar. What are the final stresses in steel and aluminium?

Given $E_S = 2 \times 10^5 \text{ N/mm}^2$, $E_A = \frac{2}{3} \times 10^5 \text{ N/mm}^2$, (12 Marks)

$\alpha_S = 12 \times 10^{-6} / ^\circ\text{C}$ and $\alpha_A = 23 \times 10^{-6} / ^\circ\text{C}$.

- b. Establish a relationship between the modulus of elasticity and modulus of rigidity. (08 Marks)

Module-2

3. a. Define i) Principal stress ii) Principal strain. (04 Marks)
- b. At a certain point in a strained material the stress condition shown in fig. Q3(b) exists. Find
 - i) Normal and shear stress on the inclined plane AB.
 - ii) Principal stresses and principal planes.
 - iii) Maximum shear stresses and their planes. (16 Marks)

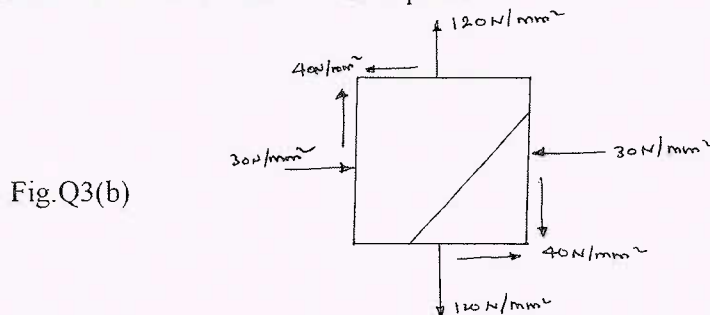

Important Note : 1. On completing your answers, compulsorily draw diagonal cross lines on the remaining blank pages.
2. Any revealing of identification, appeal to evaluator and /or equations written eg. 42+8 = 50, will be treated as malpractice.

OR

- 4 a. Derive an expression for circumferential stress and longitudinal stress for a thin cylinder subjected to an internal pressure. (08 Marks)
- b. List the difference between thin and thick cylinders. (02 Marks)
- c. A thick cylinder pipe of outside diameter 300mm and internal diameter 200mm is subjected to an internal fluid pressure 20N/mm^2 and external fluid pressure of 5N/mm^2 . Determine the maximum hoop stress developed. Draw the variation of hoop stress and radial stress across the thickness indicating the values at every 25mm interval. (10 Marks)

Module-3

- 5 a. What are different types of beams? Explain briefly. (05 Marks)
- b. Draw shear force and bending moment diagrams for the beam shown in fig. Q5(b). Locate point of contra flexure if any. (15 Marks)

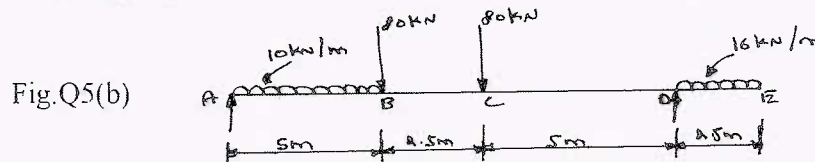

OR

- 6 a. Prove the relation $\frac{M}{I} = \frac{\sigma}{Y} = \frac{E}{R}$ with usual notations. (10 Marks)
- b. A cantilever has a length of 3m. Its cross – section is of T – section with flange $100\text{mm} \times 20\text{mm}$ and web $200\text{mm} \times 12\text{mm}$, the flange is in tension. What is the intensity of UDL that can be applied if the maximum tensile stress is limited to 30N/mm^2 ? Also compute the maximum compressive stress. (10 Marks)

Module-4

- 7 a. What are the assumption made in theory of pure torsion? (02 Marks)
- b. Derive torsion equation with usual notations. (08 Marks)
- c. A solid circular shaft has to transmit a power of 1000 kW at 120 rpm. Find the diameter of the shaft, if the shear stress of the material must not exceed 80N/mm^2 . The maximum torque 1.25 times of its mean. What percentage of saving in material would be obtained if the shaft is replaced by a hollow one whose internal diameter is 0.6 times its external diameter, the length, material and maximum shear stress being same. (10 Marks)

OR

- 8 a. Derive an expression for the critical load in a column subjected to compressive load, when both the ends are hinged. Also mention the assumptions made in the derivation. (10 Marks)
- b. Design the section of a circular cast iron column that can safely carry a load of 1000kN. The length of the column is 6 meters. Rankine's constant is $1/1000$, factor of safety is 3. One end of the column is fixed and other end is free. Critical stress is 560 MPa. (10 Marks)

Module-5

- 9 a. State Castiglione's theorem I and II. (04 Marks)
- b. Derive an expression for strain energy due to normal stress. (08 Marks)
- c. Determine the strain energy of the simply supported prismatic beam, subjected to UDL of 25kN/m over total span 10m. Assume $I = 195.3 \times 10^3 \text{ mm}^4$, $E = 2 \times 10^5 \text{ MPa}$. (08 Marks)

OR

- 10 a. Explain Maximum principal stress theory and Maximum shear stress theory. (10 Marks)
- b. The stress induced at a critical point in a machine component made of steel are as follows : $\sigma_x = 100\text{N/mm}^2$, $\sigma_y = 40\text{N/mm}^2$, $\tau_{xy} = 80\text{N/mm}^2$. Calculate the factor of safety by
 i) Maximum shear stress theory ii) Maximum normal stress theory. (10 Marks)

** 2 of 2 **

--	--	--	--	--	--	--	--	--	--

Third Semester B.E. Degree Examination, June/July 2019 Mechanical Measurements and Metrology

Time: 3 hrs.

Max. Marks: 100

Note: Answer any FIVE full questions, choosing ONE full question from each module.

Module-1

- 1 a. Explain with a neat sketch Imperial Standard Yard and International Prototype Meter. (08 Marks)
- b. Four end bars A, B, C, D of approximately 100 mm are to be calibrated using standard and calibrated length bar of 400 mm. This calibrated standard bar has actual length of 399.9998 mm. The bar B is 0.0004 mm longer than bar A, bar C is 0.0003 mm longer than bar A and bar D is 0.0001 mm shorter than bar A. The four end bars, when mounted, their combined length is found to be 0.0004 mm longer than actual length of standard bar. estimate the actual length of each bar. (08 Marks)
- c. Explain line and end standards. (04 Marks)

OR

- 2 a. Explain the principle of autocollimator with the help of a neat sketch. (08 Marks)
- b. Using a set of M112 slip gauges, build the following dimensions: (i) 49.3115 (ii) 87.3215 (04 Marks)
- c. Explain the phenomenon of wringing of slip gauges with a neat sketch. (08 Marks)

Module-2

- 3 a. With neat sketches, explain the hole based and shaft based system of limits and fits. (08 Marks)
- b. Differentiate between:
i) Interchangeability and selective assembly
ii) Unilateral and bilateral tolerance (08 Marks)
- c. Explain with neat sketches, snap gauge and ring gauge. (04 Marks)

OR

- 4 a. Explain with a neat sketch, the construction, working, advantages and disadvantages of LVDT. (10 Marks)
- b. Sketch and explain the principle and construction of Johansson Mikrokator. (10 Marks)

Module-3

- 5 a. Derive an expression for measuring the effective diameter of a screw thread using 3-wire method. (10 Marks)
- b. Derive an expression for best size wire. (05 Marks)
- c. Explain with a neat sketch gear roll to tester for composite error. (05 Marks)

OR

- 6 a. Explain the working and construction of CMM. (10 Marks)
- b. Sketch and explain laser interferometer. (06 Marks)
- c. Give the applications of CMM. (04 Marks)

Module-4

- 7 a. Explain the generalized measurement system with a block diagram and example. (10 Marks)
b. Define: (i) Accuracy (ii) Precision (iii) Linearity (iv) Loading effect (04 Marks)
c. Explain with neat sketch capacitive transducer of changing distance. (06 Marks)

OR

- 8 a. Sketch and explain Cathode Ray Oscilloscope. (08 Marks)
b. Explain with a neat sketch, Ballast circuit diagram. (08 Marks)
c. Differentiate between:
i) Primary and secondary transducer
ii) Active and passive transducer (04 Marks)

Module-5

- 9 a. Explain with a neat sketch the working principle of McLeod gauge. (08 Marks)
b. Explain prony brake dynamometer with a neat sketch. (06 Marks)
c. Explain with a neat sketch, the working of hydraulic dynamometer. (06 Marks)

OR

- 10 a. Sketch and explain the working principle of optical pyrometer. (08 Marks)
b. State the laws of thermocouple with neat sketches. (06 Marks)
c. Explain temperature compensation in resistance type strain gauge. (06 Marks)

USN

--	--	--	--	--	--	--	--

15ME33

Third Semester B.E. Degree Examination, June/July 2019 Basic Thermodynamics

Time: 3 hrs.

Max. Marks: 80

- Note: 1. Answer any FIVE full questions, choosing ONE full question from each module.
2. Use of Thermodynamic data hand book and steam table is permitted.**

Module-1

- 1 a. Distinguish between macro and microscopic point of view of thermodynamics. (05 Marks)
 b. Classify the following into intensive and extensive properties.
 i) Molecular weight ii) Enthalpy iii) Refractive index
 iv) Quality of steam v) Entropy vi) Roll strength of class. (03 Marks)
 c. Develop a linear scale '°B' where in ice and normal body temperature are assumed as two fixed points and assigned the values 0°B and 50°B respectively. If temperature of human body on Celsius scale is 36.7°C, obtain the relation between '°B' scale and °C' scale and find out boiling temperature of water in 'B' scale. (08 Marks)

OR

- 2 a. With a suitable example define work from thermodynamic point of view. (04 Marks)
 b. Prove that heat transfer is a path function. (04 Marks)
 c. The properties of a closed system changes following the relation between pressure and volume as $PV = 3.0$, where P is in bar, V is in m^3 . Calculate the work transfer, when the pressure increases from 1.5 bar to 7.5 bar. (08 Marks)

Module-2

- 3 a. Using first law of thermodynamics for non-flow system, show that the heat transfer is equal to the enthalpy change of a system during constant pressure process. (04 Marks)
 b. A housewife on a warm summer day, decided to beat heat by closing the windows and doors in the kitchen and opening the refrigerator door. At first she feels cool and refreshed, but after a while the effect begins to wear off. Evaluate the situation as it relates to 'first law of thermodynamics' considering room including the refrigerators the system. (04 Marks)
 c. A centrifugal pump delivers 50kg of water per second. The inlet and outlet pressure are 1 bar and 4.2 bar respectively. The suction is 2.2m below the centre of the pump and delivery is 8.5 above the centre of the pump. The suction and delivery pipe diameters are 20cm and 30cm respectively. Determine the capacity of the electric motor to run the pump. (08 Marks)

OR

- 4 a. Define the following :
 i) Thermal Energy Reservoir (TER).
 ii) COP of Heat pump. (04 Marks)
 b. What is PMM – 2? Why it is impossible? (04 Marks)
 c. A fish freezing plant requires 40 tons of refrigeration. The freezing temperature is -35°C, while the ambient temperature is 30°C. If the performance of the plant is 20% of the theoretical reversed Carnot cycle working within the some temperature limits, calculate power required. (08 Marks)

Module-3

- 5 a. Explain the conditions for reversibility. (03 Marks)
 b. Show that heat transfer through a finite temperature difference is irreversible. (05 Marks)

Important Note : 1. On completing your answers, compulsorily draw diagonal cross lines on the remaining blank pages.
2. Any revealing of identification, appeal to evaluator and /or equations written eg. 42+8 = 50, will be treated as malpractice.

- c. Show that the efficiencies of all reversible heat engines operating between the same temperature levels is the same. (08 Marks)

OR

- 6 a. Show that entropy is a property of system. (05 Marks)
 b. Explain the 'principle of entropy'. (03 Marks)
 c. 1 kg of ice at -5°C is exposed to the atmosphere, which is at 25°C . The ice melts and comes into thermal equilibrium. Determine the entropy increase of the universe. Take C_p of ice = $2.093\text{kJ/kg}^{\circ}\text{C}$. Latent heat of fusion of Ice = 333.33 kJ/kg . (08 Marks)

Module-4

- 7 a. What do you understand by the 'thermodynamic dead state? Explain briefly. (04 Marks)
 b. Prove that, $\eta_{II} = \frac{\eta_I}{\eta_{Carnot}}$. (04 Marks)
 c. Derive the Maxwell relations and explain their importance in thermodynamics. (08 Marks)

OR

- 8 a. Define the following terms with reference to pure substance.
 i) Saturation temperature
 ii) Latent heat of vaporization
 iii) Critical point
 iv) Trip point (02 Marks)
 b. With neat sketch, explain the measurement of dryness fraction of steam by using 'Throttling Calorimeter'. (06 Marks)
 c. Two boilers one with superheater and other without superheater are delivering equal quantities of steam into common main. The pressure in the boilers and main is 20bar. The temperature of steam from a boiler with a superheater is 350°C and temperature of the steam in the main is 250°C . Determine the quality of steam supplied by the other boiler. Take $C_{ps} = 2.5\text{kJ/kgk}$. (08 Marks)

Module-5

- 9 a. Show that for an ideal gas, $C_p - C_v = R$. (06 Marks)
 b. A mass of air is initially at 260°C and 700KPa , and occupies 0.028m^3 . The air is expanded at constant pressure to 0.084m^3 . A polytropic process with $n = 1.5$ is then carried out, followed by a constant temperature process which completes a cycle. All the process are reversible.
 i) Sketch the cycle in the P-V and T-S plane.
 ii) Find the heat received and heat rejected in the cycle
 iii) Efficiency of cycle. (10 Marks)

OR

- 10 a. State 'Dalton's law of partial pressure'. (02 Marks)
 b. Define the following terms :
 i) Saturated air ii) Wet bulb temperature
 iii) Specific humidity iv) Dew point temperature. (06 Marks)
 c. A mixture of gas has the following volumetric analysis. $\text{O}_2 = 30\%$, $\text{CO}_2 = 40\%$, $\text{N}_2 = 30\%$. Determine : i) The analysis on a mass basis ii) the partial pressure of each component, if the total pressure is 100KPa and temperature is 32°C . iii) the molecular weight of mixture. (08 Marks)

* * * * *

Third Semester B.E. Degree Examination, June/July 2019 Mechanics of Materials

Time: 3 hrs.

Max. Marks: 80

Note: Answer any FIVE full questions, choosing ONE full question from each module.

Module-1

- 1 a. Derive an expression for the extension of uniformly tapering circular bar subjected to axial load. (08 Marks)
- b. A stepped bar made up of steel and brass is subjected to a pull of 30 kN as shown in Fig.Q1(b). Determine the deformation of each material and stress in each material. Take $E_S = 200 \text{ GPa}$, $E_B = 100 \text{ GPa}$.

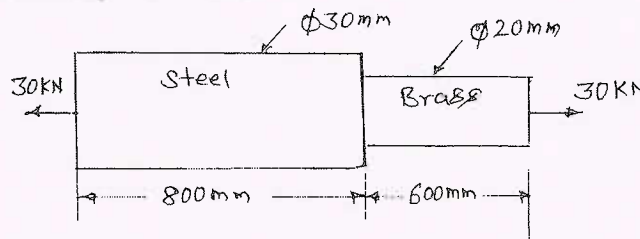

Fig.Q1(b)

(08 Marks)

OR

- 2 a. Define: i) Young's modulus ii) Bulk modulus iii) Poisson's ratio iv) Thermal stress (08 Marks)
- b. A bar of 20 mm diameter is tested in tension. It is observed that when a load of 37.7 kN is applied, the extension measured over a gauge length of 200 mm is 0.12 mm and contraction in diameter is 0.0036 mm. Determine: i) Lateral strain ii) Poisson's ratio iii) Elastic moduli E, G, K. (08 Marks)

Module-2

- 3 a. Define or explain (i) Principal plane (ii) Principal stress (iii) Plane of maximum shear (iv) Maximum shear stress. (08 Marks)
- b. For a two dimensional stressed element shown in Fig.Q3(b), determine principal stresses, principal planes, maximum shear stress and maximum shear stress planes.

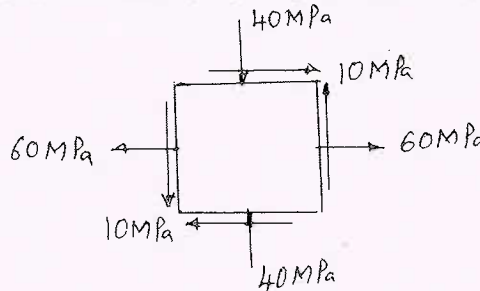

Fig.Q3(b)

(08 Marks)

OR

- 4 a. Derive expressions for circumferential and longitudinal strains in thin cylinder. Hence show that volumetric strain $\epsilon_v = \frac{pd}{4tE} (5 - 4\mu)$ with usual notations. (08 Marks)

- b. A thick cylinder of outside diameter 300 mm and internal diameter 200 mm is subjected to an internal fluid pressure of 14 MPa. Determine the maximum hoop stress developed. Also sketch the variation of hoop stress and radial pressure across the thickness of the cylinder. (08 Marks)

Module-3

- 5 a. Derive an expression to establish a relationship between the intensity of load, shear force and bending moment. (06 Marks)
- b. Draw SFD and BMD for the overhang beam shown in Fig.Q5(b). Indicate all the significant values.

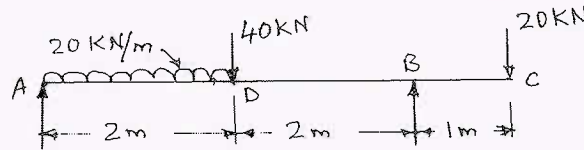

Fig.Q5(b)

(10 Marks)

OR

- 6 a. Write bending equation and explain each notation with units. Also list the assumptions made in theory of simple bending. (08 Marks)
- b. A cantilever beam of square section 200 mm × 200 mm, of length 2 m just fails in flexure when a load of 12 kN is placed at its free end. A beam of same material and having cross section 150 mm wide and 300 mm deep is simply supported over a span of 3m. Determine the minimum central point load required to break the beam. (08 Marks)

Module-4

- 7 a. Derive the torsion equation for a circular shaft with usual notations. (08 Marks)
- b. A solid shaft is required to transmit 112.5 KW power at 150 rpm. The diameter of the shaft is 100 mm and length is 10 m long. Determine the maximum intensity of shear stress and the angle of twist. Take $G = 82 \text{ GPa}$. (08 Marks)

OR

- 8 a. Derive an expression for Euler's critical load for a column whose both ends are hinged. (08 Marks)
- b. A column of circular cross section of 50 mm diameter is 1.5 m long. One end of the column is fixed and other end is free. Determine the critical load using:
 i) Euler's formula taking $E = 120 \text{ GPa}$
 ii) Rankines formula taking $\sigma_c = 560 \text{ N/mm}^2$ and constant $a = 1/1600$. (08 Marks)

Module-5

- 9 a. State Castigliano's theorem I and II. (04 Marks)
- b. Define strain energy and modulus of resilience. (04 Marks)
- c. Calculate the strain energy stored in the bar shown in Fig.Q9(c) subjected to an axial force of 5 kN. Take $E = 2 \times 10^5 \text{ N/mm}^2$.

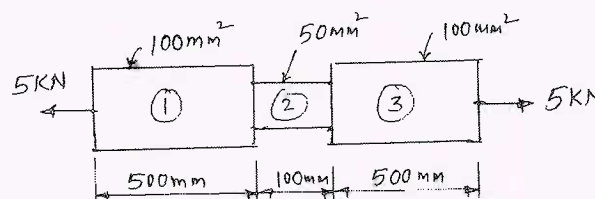

Fig.Q9(c)

(08 Marks)

OR

- 10 a. Determine the deflection at the free end of a Cantilever beam of length L carrying a point load W at its free end. Use strain energy method. (08 Marks)
- b. Explain: i) Maximum principal stress theory ii) Maximum shear stress theory. (08 Marks)

USN

--	--	--	--	--	--	--	--	--	--

15ME35A

Third Semester B.E. Degree Examination, June/July 2019 Metal Casting and Welding

Time: 3 hrs.

Max. Marks: 80

Note: Answer any FIVE full questions, choosing ONE full question from each module.

Module-1

- 1 a. With a neat [sketch] flowchart and explain the steps involved in casting process. (08 Marks)
b. What are pattern allowance? Explain any two pattern allowance with a neat sketch. (08 Marks)

OR

- 2 a. Explain with a neat sketch sheet mould and CO₂ mould process. (08 Marks)
b. Write down the advantages and limitations of green sand moulds. (08 Marks)

Module-2

- 3 a. Explain the construction and working principle of cupola furnace with a neat sketch. (10 Marks)
b. How the melting furnaces classified? Give the basis and list them. (06 Marks)

OR

- 4 a. Explain with a neat sketch the working of cold chamber die casting. (08 Marks)
b. Explain with a neat sketch the principle of a continuous casting process. (08 Marks)

Module-3

- 5 a. Explain the directional solidification needs and its methods. (08 Marks)
b. Explain degassing in liquid melt technology and sources of degassing. List out the degassing agents used. (08 Marks)

OR

- 6 a. Explain the sand casting defects causes, features and remedies. (08 Marks)
b. Explain with a neat sketch working and principle of stir casting techniques adapted for composites. (08 Marks)

Module-4

- 7 a. What is welding? Mention the advantages and limitations of welding process. (08 Marks)
b. Explain with a neat sketch TIG welding. Mention its advantages and limitations. (08 Marks)

OR

- 8 a. What are special welding process? How they are classified? What are the advantages and limitations of special welding process? (08 Marks)
b. Explain with a neat sketch the principle process and application of projection welding. (08 Marks)

Important Note : 1. On completing your answers, compulsorily draw diagonal cross lines on the remaining blank pages.
2. Any revealing of identification, appeal to evaluator and /or equations written eg. 42+8 = 50, will be treated as malpractice.

Module-5

- 9 a. Write short notes on:
- (i) HAZ (Explain heat affected Zone with figure) (05 Marks)
 - (ii) What is Residual Stresses in Welding (03 Marks)
- b. Mention the advantages and disadvantages of soldering and brazing. (08 Marks)

OR

- 10 a. Explain the inspection methods with sketches:
- (i) Magnetic particle inspection (08 Marks)
 - (ii) Radiography Technique (08 Marks)
- b. Explain with a sketch of Oxy-Acetylene welding with application. (08 Marks)

--	--	--	--	--	--	--	--	--	--

Third Semester B.E. Degree Examination, June/July 2019 Mechanical Measurements and Metrology

Time: 3 hrs.

Max. Marks: 80

Note: Answer any FIVE full questions, choosing ONE full question from each module.

Module-1

- 1 a. What is metrology? State any two objectives of metrology. (04 Marks)
b. What is the difference between accuracy and precision? (04 Marks)
c. Four length bars of basic length 100mm are to be calibrated using a calibrated length bar of 400mm whose actual length is 399.9992mm. It was also found that lengths of bars B, C and D in comparison to A are +0.0002mm, +0.0004mm and -0.0001mm respectively and the length of all the four bars put together in comparison to standard calibrated bar is +0.0003mm longer. Determine the actual dimensions of all the four end bars. (08 Marks)

OR

- 2 a. Describe the steps in wringing of slip gauges. (04 Marks)
b. Build the following dimensions using M87 set slip gauges: i) 49.3825mm ii) 87.3215mm. (06 Marks)
c. With a sketch explain the method of measuring taper angles using sine centre. (06 Marks)

Module-2

- 3 a. Differentiate between interchangeability and selective assembly. (04 Marks)
b. Discuss 'Hole based' and 'Shaft based' system of fits with sketches. (08 Marks)
c. State and explain Taylor's principle of gauge design. (04 Marks)

OR

- 4 a. Mention any three important functional requirements of a comparators. (03 Marks)
b. Explain with sketch a dial indicator. (05 Marks)
c. Explain with a sketch the working of a Solex Pneumatic comparator. (08 Marks)

Module-3

- 5 a. What is best size wire? (02 Marks)
b. How do you find effective diameter of a screw thread using two-wire method? (06 Marks)
c. With a neat sketch show all the terminologies of a spur gear. Explain how concentricity of a gear teeth is measured. (08 Marks)

OR

- 6 a. State any four advantages of lasers. (02 Marks)
b. Discuss the important features and applications of co-ordinate measuring machine. (08 Marks)
c. Sketch and label the parts of laser interferometer. (06 Marks)

Module-4

- 7 a. What is the significance of measurement system? (04 Marks)
b. How errors are classified? Explain each type with example. (07 Marks)
c. Mention any five mechanical and five electrical transducers. (05 Marks)

1 of 2

Important Note : 1. On completing your answers, compulsorily draw diagonal cross lines on the remaining blank pages.
2. Any revealing of identification, appeal to evaluator and/or equations written eg, 42+8 = 50, will be treated as malpractice.

OR

- 8 a. With an example explain a mechanical intermediate modifying device. (04 Marks)
b. Describe in detail a Ballast circuit. (06 Marks)
c. With a sketch explain any one type oscillograph. (06 Marks)

Module-5

- 9 a. What are the methods of force measurement? Give example. (04 Marks)
b. With the help of neat sketch explain the working principle of prony brake dynamometer. (06 Marks)
c. Give the working principle of pirani gage with neat sketch. (06 Marks)

OR

- 10 a. What are the steps to be taken in the preparation of the specimen and mounting of strain gauges? (06 Marks)
b. Explain with a neat sketch any one mechanical type strain gauge. (06 Marks)
c. State and explain law of intermediate temperatures. (04 Marks)

* * * * *

CBCS SCHEME

USN

--	--	--	--	--	--	--	--	--	--

15ME/MA32

Third Semester B.E. Degree Examination, June/July 2019 Material Science

Time: 3 hrs.

Max. Marks: 80

Note: Answer any FIVE full questions, choosing ONE full question from each module.

Module-1

- 1 a. Show that the atomic packing factor for HCP is 0.74. (05 Marks)
- b. Define the following : i) Diffusion flux ii) Fracture toughness iii) Proof stress
iv) Strain hardening. (04 Marks)
- c. A steel tank in a process industry contains nitrogen at 400⁰K and at a constant pressure of 15 atm. Vacuum exists outside the tank. Nitrogen concentration at the inner surface of the tank is equal to 12 kg/m³. The constant $D_0 = 5 \times 10^{-7} \text{ m}^2/\text{s}$ and activation energy for diffusion process between nitrogen and steel is 75 kJ/mol. Calculate the rate at which nitrogen escapes through the tank wall. The thickness of tank wall is 6mm. (07 Marks)

OR

- 2 a. A cylindrical specimen of steel having an original diameter of 12.8mm is tensile tested to fracture and found to have an engineering fracture strength σ_f of 460 MPa. If the cross sectional diameter at fracture is 10.7mm determine i) the ductility in terms of percent reduction in area ii) the true stress at fracture. (04 Marks)
- b. Explain the mechanisms of strengthening in metals. (06 Marks)
- c. Explain the following : i) Twin boundaries ii) S-N diagram iii) Three stages of creep. (06 Marks)

Module-2

- 3 a. Explain Hume Rothery conditions for unlimited solid solubility. (04 Marks)
- b. Explain the mechanism of solidification. (06 Marks)
- c. Calculate the amounts of α , L at 1250⁰C in the $C_{Ni} - 40\% \text{ Ni}$ alloy shown in fig. Q3(c). (06 Marks)

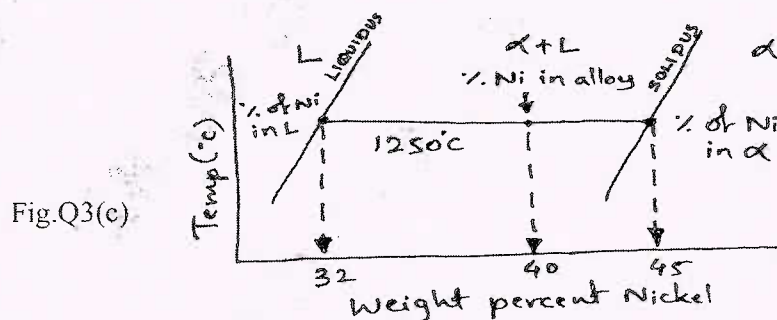

OR

- 4 a. Explain Eutectic system with a neat sketch in a Binary phase diagram. (08 Marks)
- b. Distinguish between substitutional and interstitial solid solution, with a neat sketch. (08 Marks)

Important Note : 1. On completing your answers, compulsorily draw diagonal cross lines on the remaining blank pages.
2. Any revealing of identification, appeal to evaluator and /or equations written eg. 42+8 = 50, will be treated as malpractice.

Module-3

- 5 a. Draw Iron – Carbon equilibrium diagram upto 6.67% carbon. (08 Marks)
 b. Explain Annealing, with neat sketch. (05 Marks)
 c. List the purpose of normalizing. (03 Marks)

OR

- 6 a. Explain Age hardening of Al - Cu alloys, with neat sketch. (08 Marks)
 b. List the properties and composition of SG Iron and Steel. (08 Marks)

Module-4

- 7 a. Explain functional and structural classification of ceramic materials. (05 Marks)
 b. Explain Electrical and thermal properties of ceramic materials. (05 Marks)
 c. Write short notes on the following :
 i) Biocompatible materials
 ii) Direct and converse effect in piezoelectric material. (06 Marks)

OR

- 8 a. What is Smart material? Why piezoelectric material and SMA material are termed as Smart materials. (04 Marks)
 b. Explain briefly the following : i) Super elasticity ii) Mechanical behaviour of plastics iii) Fiber optics materials. (06 Marks)
 c. Differentiate between Thermosetting and Thermoplastic materials. (06 Marks)

Module-5

- 9 a. Are composite materials isotropic and / or homogeneous? Explain. (04 Marks)
 b. Evaluate expression for longitudinal Young's modulus of unidirectional lamina using strength of materials approach. (06 Marks)
 c. Explain the merits and demerits of MMC's. (06 Marks)

OR

- 10 a. Explain the classification of composite materials. (06 Marks)
 b. What is Hybrid composite? Explain the types of hybrid laminates. (04 Marks)
 c. Explain the applications of the following :
 i) Ceramic metal composites.
 ii) Metal matrix composites.
 iii) Polymer matrix composites. (06 Marks)

* * * * *

Third Semester B.E. Degree Examination, June/July 2019
Mechanics of Materials

Time: 3 hrs.

Max. Marks: 100

**Note: Answer any FIVE full questions, selecting
atleast TWO questions from each part.**

PART – A

- 1 a. Define the following : (i) Plasticity (ii) Ductility (iii) Brittleness (iv) Malleability (v) Toughness (vi) Hardness. (06 Marks)
- b. If a tension test bar is found to taper from (D + a) diameter to (D - a) diameter, over a length 'L'. Derive an expression for extension of bar. (06 Marks)
- c. A stepped bar with three different portions has a fixed support at one of its ends. The stepped bar is subjected to forces as shown in Fig.Q1(c). Determine the stresses and deformations induced in each portion. Also find the net deformation induced in the stepped bar. Take $E = 200 \text{ GPa}$. (08 Marks)

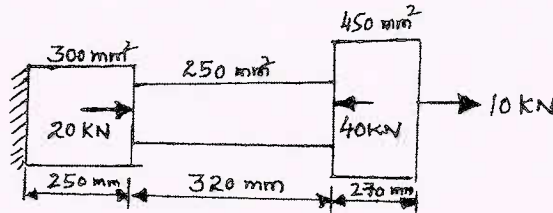

Fig.Q1(c)

- 2 a. Determine the changes in length, width and thickness of a steel bar which is 4 m long, 30 mm wide and 20 mm thick and is subjected to an axial pull of 30 kN in the direction of length. $E = 2 \times 10^5 \text{ N/mm}^2$ and Poisson's ratio = 0.3. Also determine the volumetric strain, change in volume and final volume of the given bar. (10 Marks)
- b. A composite bar made up of aluminium and steel is held between two supports as shown in Fig.Q2(b). The bars are stress free at a temperature of 42°C . What will be the stresses in the two bars with the temperature drops to 24°C if (a) the supports are unyielding (b) the supports come nearer to each other by 0.1 mm. The cross sectional area of steel bar is 160 mm^2 and that of aluminium bar is 240 mm^2 . $E_A = 0.7 \times 10^5 \text{ N/mm}^2$, $E_S = 2 \times 10^5 \text{ N/mm}^2$. $\alpha_A = 24 \times 10^{-6} \text{ per } ^\circ\text{C}$ and $\alpha_S = 12 \times 10^{-6} \text{ per } ^\circ\text{C}$ (10 Marks)

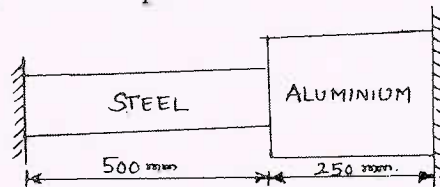

Fig.Q2(b)

- 3 a. At a point in a strained material, the principal tensile stresses across two perpendicular planes are 80 N/mm^2 and 40 N/mm^2 . Determine the normal stress, shear stress and the resultant stress on a plane inclined at 20° with major principal plane. Determine also the angle of obliquity. What will be the intensity of stress which acting alone will produce the same maximum strain if Poisson's ratio = $1/4$. (10 Marks)

- b. The state of stress in a strained material is as shown in Fig.Q3(b). Determine the normal, tangential and resultant stresses on plane DE by Mohr's circle method. Also determine the direction of resultant stress. (10 Marks)

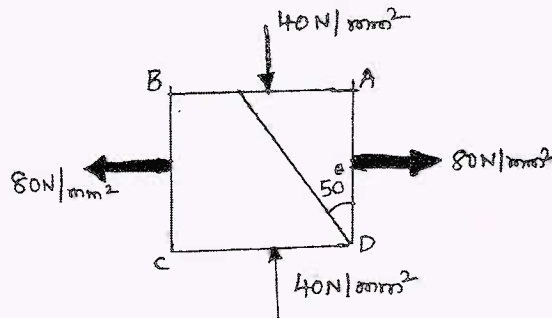

Fig.Q3(b)

- 4 a. Define the following : (i) Strain energy (ii) Proof Resilience (iii) Modulus of resilience. (03 Marks)
- b. Show that in a bar, subjected to an axial load, the instantaneous stress due to sudden application of a load is twice the stress caused by the gradual application of load. (07 Marks)
- c. A thick cylinder of internal diameter 160 mm is subjected to an internal pressure 40 N/mm². If the allowable stress in the material is 120 N/mm². Find the thickness required. (10 Marks)

PART – B

- 5 a. Define the following : (i) Bending moment (ii) Shear force (iii) Point of contraflexure. (06 Marks)
- b. A beam 5 m long and simply supported at each end, has a uniformly distributed load of 1000 N/m extending from the left end to a point 2 m away. There is also a clockwise couple of 1500 N-m applied at the centre of the beam. Draw the shear force and bending moment diagrams for the beam and find the maximum bending moment. Neglect the weight of the beam. (14 Marks)
- 6 a. A cast iron beam has an I-section with top flange 80mm×40mm, web 120mm×20mm and bottom flange 160mm×40mm. If tensile stress is not to exceed 30 N/mm² and compressive stress 90 N/mm², what is the maximum uniformly distributed load the beam can carry over a simply supported span of 6m if the larger flange is in tension? (12 Marks)
- b. Show that for a rectangular section, the distribution of shearing stress is parabolic. (08 Marks)
- 7 a. Derive a relation for the slope and deflection of a simply supported beam subjected to a uniformly distributed load of W/m length. (10 Marks)
- b. A simply supported beam of span 10m is carrying a point load of 10 kN at a distance of 6m from the left end. If $E = 200 \text{ GN/m}^2$ and $I = 1000 \times 10^6 \text{ mm}^4$, determine :
 (i) Slope at the left end (ii) Deflection under the load and
 (iii) Maximum deflection of the beam (10 Marks)
- 8 a. A hollow circular shaft of 6m length and inner and outer diameter of 75 mm and 100mm is subjected to a torque of 10 kN-m. If $G = 80 \text{ GPa}$, determine the maximum shear stress produced and the total angle of twist. (10 Marks)
- b. Derive a relation for the Euler's crippling load for a column when it has both ends hinged. (10 Marks)

- b. In Fig.Q5(a), if $r_2 = 100\text{mm}$, $r_3 = 350\text{mm}$, $\theta_2 = 60^\circ$, find angular velocity and angular acceleration of connecting rod if crank rotates uniformly at 600 rpm in CCW direction. (12 Marks)

OR

- 6 a. For the 4-bar mechanism shown in Fig.Q6, obtain Freudenstein's equation. (08 Marks)

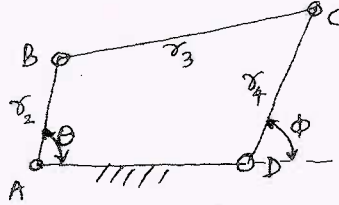

Fig.Q6

- b. Find r_2 , r_3 and r_4 to generate a function $y = x^3$, $1 \leq x \leq 3$ accurate at $x = 1.1339$, $x = 2$ and $x = 2.866$ if $r_1 = 100\text{mm}$, $\theta_s = 30^\circ$, $\theta_f = 90^\circ$, $\phi_s = 45^\circ$ and $\phi_f = 135^\circ$ with respect to Fig.Q6. (12 Marks)

Module-4

- 7 a. Define 'pitch circle', 'circular pitch', 'diametral pitch' and 'module'. (08 Marks)
b. Obtain an expression for the minimum number of teeth on pinion to avoid interference. (12 Marks)

OR

- 8 An epicyclic gear train consists of a sun-wheel S, a stationary internal gear E and three identical planet wheels P carried on a star shaped planet carrier C. The size of different tooth wheels are such that the planet carrier C rotates at $1/5^{\text{th}}$ of the speed of the sunwheel S. The no. of teeth on sun-wheel is 16. The driving torque on the sun-wheel is 100 N-m. Determine (i) no. of teeth on P and E. (ii) Torque required to keep the internal gear stationary. (20 Marks)

Module-5

- 9 From the following data draw the profile of a cam in which the follower moves with SHM during ascent while it moves with uniform acceleration and deceleration during descent.
Cam rotates in anticlockwise ; Lift of follower : 4 cm
Least radius of cam : 5 cm ; Angle of ascent : 48°
Angle of dwell between ascent and descent : 42° ;
Angle of descent = 60°
The diameter of roller = 3 cm
If cam rotates at 360 rpm, find maximum velocity and acceleration of the follower during descent. (20 Marks)

OR

- 10 a. Explain with sketch in brief 'radial cam' and 'cylindrical cam'. (06 Marks)
b. Obtain expressions for displacement, velocity and acceleration for a flat faced follower in contact with circular flank of a cam. (14 Marks)

* * * * *

CBCS SCHEME

USN

2 V D I 7 M E O O 1

17ME43

Fourth Semester B.E. Degree Examination, June/July 2019

Applied Thermodynamics

Time: 3 hrs.

Max. Marks: 100

- Note: 1. Answer any FIVE full questions, choosing ONE full question from each module.
2. Use of Thermodynamic data hand book is permitted.*

Module-1

- 1 a. Draw neat P-V and T-S diagram of air standard dual cycle and derive an expression for air standard efficiency in terms of compression ratio, explosion ratio and cut-off ratio. Under what conditions the dual cycle becomes Otto and Diesel cycle. (10 Marks)
- b. An air standard diesel cycle has a compression ratio 16. The temperature before compression is 27°C and the temperature after expansion is 627°C. Compute:
- Cut-off ratio
 - The net work output per unit mass of air
 - Thermal efficiency
 - Mean effective pressure in bar.



(10 Marks)

OR

- 2 a. Explain with schematic diagram and T-S diagram Brayton cycle with i) Regenerator and ii) Inter-cooler and write equation for the thermal efficiency. (10 Marks)
- b. Derive an expression for optimum pressure ratio and maximum pressure ratio for maximum work output in terms of minimum temperature, maximum temperature of Brayton cycle and what is the relation between the two. (10 Marks)

Module-2

- 3 a. With the help of schematic diagram, T-S diagram and h-s diagram, explain regenerative vapour power cycle with one open feed water heater and derive an expression for its thermal efficiency. (10 Marks)
- b. A simple Rankine cycle works between the boiler pressure of 30bar and condenser pressure of 0.04Bar. The supply steam to the turbine is dry saturated, determine Rankine cycle efficiency. If the supply steam to the turbine is superheated by 66°C, what is the effect on the Rankine efficiency? (10 Marks)

OR

- 4 a. With the help of schematic diagram and T-S diagram explain binary vapour power cycle. List the properties of an ideal binary fluid. (10 Marks)
- b. A reheat cycle operating between 30 bar and 0.04 bar pressure. The temperature of steam supplied from boiler is 450°C. The first stage of expansion takes place till the steam is dry saturated and then reheated to 450°C and then expanded in second in stage. Determine:
- Reheat pressure
 - Quality of exhaust steam
 - Ideal cycle efficiency
 - Steam Rate
 - Back-pressure ratio.

(10 Marks)

1 of 3

Important Note : 1. On completing your answers, compulsorily draw diagonal cross lines on the remaining blank pages.
2. Any revealing of identification, appeal to evaluator and /or equations written eg, 42+8 = 50, will be treated as malpractice.

Module-3

- 5 a. List the methods used for finding out indicated power of an internal combustion engine. Explain the method applicable to multi-cylinder engine. (08 Marks)
- b. The products of combustion of an unknown hydrocarbon C_xH_y have the following composition as measured by an Orsat's apparatus:
 $CO_2 = 8\%$, $CO = 0.9\%$, $O_2 = 8.8\%$, $N_2 = 82.3\%$. Determine:
 i) The composition of fuel
 ii) A:F ratio
 iii) The percentage excess air used. (12 Marks)

OR

- 6 a. Explain the following terms with reference to a combustion process:
 i) Enthalpy of formation
 ii) Adiabatic flame temperature
 iii) Combustion efficiency
 iv) Stoichiometric air. (08 Marks)
- b. A gas engine working on constant volume cycle gave the following results during a one hour test run:
 Cylinder diameter : 24cm, stroke 48cm, effective diameter of brake drum 1.25m, net load on the brake 1236N, Average speed 226.7 RPM, Average explosions per minute 77, MEP 7.5 bar, gas used $13m^3$ at $15^\circ C$ and 771 mm of mercury pressure, calorific value of gas $22000 kJ/m^3$ at NTP. Cooling water used 625kg, rise in temperature of cooling water $35^\circ C$. Determine, mechanical efficiency, brake thermal efficiency indicated thermal efficiency, also draw up a heat balance sheet for the engine on percentage basis. Take NTP conditions as 760mm of mercury and $0^\circ C$. (12 Marks)

Module-4

- 7 a. With the help of schematic diagram and appropriate psychrometric diagram explain summer air conditioning system for hot and dry outdoor condition. (10 Marks)
- b. A vapor compression plant uses R-12 and is to develop 5 tonnes of refrigeration. The condenser and evaporator temperature are to be $40^\circ C$ and $-10^\circ C$ respectively. The vapor is dry saturated at compressor inlet and there is no under cooling. Determine:
 i) Refrigerant flow rate in kg/sec
 ii) The compressor discharge temperature
 iii) The pressure ratio
 iv) COP of the plant. (10 Marks)

OR

- 8 a. Explain the following with the help of P-h and T-S diagram the effect of under cooling the liquid refrigerant and super heating the vapor refrigerant on the performance of VCR cycle. (10 Marks)
- b. It is required to design an air conditioning plant for a office room with the following conditions:
 Outdoor conditions – $14^\circ C$ DBT and $10^\circ C$ WBT
 Required conditions – $20^\circ C$ DBT and 60% RH
 Amount of air circulation – $0.30m^3/min/person$
 Seating capacity of office – 60 persons.
 The required condition is achieved by heating and then by adiabatic humidification. Determine: i) Heating capacity of the coil in KW and surface temperature required if the bypass factor of the coil is 0.4 ii) The capacity of the humidifier. Also draw the flow diagram. (10 Marks)

Module-5

- 9 a. Obtain an expression for the volumetric efficiency of a single stage air compressor in terms of pressure ratio, clearance and 'h' the exponent of expansion and compression. Why intercooling is necessary in multistage compression? (10 Marks)
- b. A single stage single acting air compressor has cylinder bore of 15cm and Piston stroke of 25cm. The crank speed is 600rpm. The air taken from the atmosphere is at 1 bar and 27°C and delivered at 11 bar. Assuming both expansion and compression processes are according to the law $PV^{1.25} = \text{constant}$ and clearance is 5%. Determine: i) Power required to drive the compressor, assuming mechanical efficiency as 80%; ii) What will be change in power required to drive the compressor if clearance is 10% with other conditions remaining same. (10 Marks)

OR

- 10 a. What is critical pressure ratio? Derive an expression for pressure ratio which gives maximum discharge through the nozzle. (10 Marks)
- b. The steam expands from 3 bar to 1 bar in a nozzle. The initial velocity is 90m/s and initial temperature is 150°C. Determine the exit velocity of steam:
- If expansion is isentropic in nozzle
 - The nozzle efficiency is 95%. (10 Marks)

USN

--	--	--	--	--	--	--	--	--	--

Fourth Semester B.E. Degree Examination, June/July 2019 Fluid Mechanics

Time: 3 hrs.

Max. Marks: 100

Note: Answer any FIVE full questions, choosing ONE full question from each module.

Module-1

- 1 a. Define the following properties of fluids with their SI units:
(i) Mass Density (ii) Weight Density (iii) Dynamic viscosity (iv) Kinematic viscosity. (08 Marks)
- b. Derive an expression for pressure intensity in case of a soap bubble. (04 Marks)
- c. A cubical block of sides 1m and weighing 350 N slides down on inclined plane with a uniform velocity of 1.5 m/s. The inclined plane is laid on a slope of 5 vertical to 12 horizontal and has an oil film of 1.0mm thickness. Calculate the dynamic viscosity of oil in poise. (08 Marks)

OR

- 2 a. Define (i) Buoyancy (ii) Centre of Buoyancy (iii) Meta-centre (iv) Meta-centric height. (08 Marks)
- b. Explain the method to find the Meta-centric height experimentally. (04 Marks)
- c. A block of wood of specific gravity 0.7 floats in water. Determine the Meta-centric height of the block, if its size is 2m × 1m × 0.8m. (08 Marks)

Module-2

- 3 a. Explain different types of fluid flows with examples. (08 Marks)
- b. Derive the continuity equation for the 3-Dimensional flow in Cartesian co-ordinates. (08 Marks)
- c. A stream function is given by $\psi = 3xy$. Determine whether the flow is possible or not. (04 Marks)

OR

- 4 a. Derive an expression for force exerted by the jet on stationary flat vane. (04 Marks)
- b. Derive Euler's equation of motion along a stream line and deduce Bernoulli's equation. State the assumptions made. (10 Marks)
- c. A sub-marine moves horizontally in sea, A pitot static tube placed in front of sub-marine and along its axis is connected to the two limbs of U-tube manometer containing mercury. The difference of mercury level is found to be 200mm. Find the speed of the sub-marine in km/hr. take specific of gravity of mercury as 13.6 and sea water as 1.026, $C_v = 0.98$. (06 Marks)

Module-3

- 5 a. Derive Hagen-Poiseuille's equation for laminar flow through a circular pipe. (10 Marks)
- b. Oil is to be transported from a tanker to the shore at the rate of 5 lt/sec, using a 300mm diameter pipe for 20km length. If $\mu = 0.1 \text{ N-m/s}^2$ and $\rho = 900 \text{ kg/m}^3$ for the oil, calculate the power required to maintain the flow. (10 Marks)

Important Note : 1. On completing your answers, compulsorily draw diagonal cross lines on the remaining blank pages.
2. Any revealing of identification, appeal to evaluator and /or equations written eg. 42+8 = 50, will be treated as malpractice.

OR

- 6 a. Write a short note on Moody's diagram. (04 Marks)
- b. Three pipes of lengths 800m, 500m and 400m and diameters 500mm, 400mm and 300mm respectively are connected in series. These pipes are replaced by a single pipe of 1700m length. Find the diameter of the single pipe. (06 Marks)
- c. Water is supplied to the inhabitants of a college campus through a supply main. The following data is obtained:
- Distance of the reservoir from the campus = 4 km
 - Number of inhabitants = 3000
 - Consumption of water per day of each inhabitant = 180 litre.
 - Loss of head due to friction = 18 m
 - Co-efficient of friction for the pipe, $f = 0.007$
- If half of the daily supply is pumped in 08 hours, determine the size (diameter) of the supply main. (10 Marks)

Module-4

- 7 a. Define the drag force and lift force. Also derive their expressions. (10 Marks)
- b. Derive an expression for displacement thickness and momentum thickness of a flow over a flat. (10 Marks)

OR

- 8 a. Explain the dimensional homogeneity with examples. (04 Marks)
- b. Check whether the following equations (with their usual notations) are dimensionally homogeneous or not:

$$(i) V = \sqrt{2gh} \quad (ii) h_r = \frac{4fLV^2}{2gd} \quad (iii) P = WQH \quad (06 \text{ Marks})$$

- c. Show by the method of dimensional analysis that, for a screw propeller, the relation between the thrust 'F', torque 'T', diameter 'D', speed of travel 'U', speed of rotation 'N', density ' ρ ' and viscosity ' μ ' may be put in the form

$$F = \rho D^2 U^2 \phi \left[\frac{\rho D^3 U^2}{T}, \frac{DN}{U}, \frac{\rho UD}{\mu} \right]$$

[Hint: take D, U and ρ as repeating variables.]

(06 Marks)

Module-5

- 9 a. Define the following terms:
(i) Sub-Sonic flow (ii) Sonic flow (iii) Super-Sonic flow (iv) Mach Number (08 Marks)
- b. Derive an expression for velocity of sound in terms of Bulk modulus. (06 Marks)
- c. An aeroplane flying at a height of 15 km, where the temperature is -50°C . The speed of the plane corresponding to Mach number is 2.0. Assuming $K = 1.4$ and $R = 287 \text{ J/kg.K}$, find the speed of the plane. (06 Marks)

OR

- 10 a. Explain the necessity of CFD. Mention its applications and limitations. (10 Marks)
- b. What are normal and oblique shocks? Explain. (04 Marks)
- c. Find the velocity of a bullet fired in air, if the Mach angle is 30° . Temperature of air is 15°C . Assume $K = 1.4$ and $R = 287.14 \text{ J/kg.K}$. (06 Marks)

USN

--	--	--	--	--	--	--	--	--	--

Fourth Semester B.E. Degree Examination, June/July 2019 Metal Casting and Welding

Time: 3 hrs.

Max. Marks: 100

*Note: Answer any FIVE full questions, choosing
ONE full question from each module.*

Module-1

- 1 a. Define manufacturing process. How are manufacturing process classified? (07 Marks)
b. Briefly discuss the steps involved in making a casting. (06 Marks)
c. What are the different allowances given on a pattern? Explain briefly. (07 Marks)

OR

- 2 a. Discuss the importance of binders and additives in sand moulding. (05 Marks)
b. Sketch and explain Joult type moulding machine. (08 Marks)
c. With neat sketches explain investment casting process. (07 Marks)

Module-2

- 3 a. How are melting furnaces classified? (04 Marks)
b. With a neat sketches explain:
i) Coreless Induction furnace
ii) Electric Arc furnace. (16 Marks)

OR

- 4 a. Differentiate between gravity and pressure die casting process. (06 Marks)
b. Explain with a neat sketch horizontal type centrifugal casting process. (07 Marks)
c. With a neat sketch, explain continuous casting process. (07 Marks)

Module-3

- 5 a. Define solidification. Explain in detail the mechanism of solidification. (08 Marks)
b. How does the chills promote directional solidification? (04 Marks)
c. Explain in detail different degasification methods. (08 Marks)

OR

- 6 a. Write explanatory note on casting defects, its causes and remedies. (08 Marks)
b. Explain with a neat sketch melting of aluminium using lift-out type crucible furnace. (07 Marks)
c. Explain with a neat sketch stir casting setup. (05 Marks)

Module-4

- 7 a. Define welding. Explain applications, advantages and limitations of welding process. (08 Marks)
b. Explain: i) Tungsten Inert Gas Welding (TIG) ii) Metal Inert Gas Welding (MIG). (08 Marks)
c. Explain with a neat sketch submerged arc welding process. (04 Marks)

OR

- 8 a. Explain the principle of resistance welding. List the types of resistance welding. (04 Marks)
b. Sketch and explain the following welding process: i) Spot welding ii) Seam welding. (10 Marks)
c. Explain with neat sketches explosive welding process. (06 Marks)

Module-5

- 9 a. Discuss parameters affecting Heat Affecting Zone (HAZ). (04 Marks)
b. Write a note on:
i) Electrodes
ii) Filler rod and fluxes. (08 Marks)
c. Explain the different welding defects, its causes and remedies. (08 Marks)

OR

- 10 a. Explain with neat sketch oxy-acetylene welding process and also discuss on types of flames formed. (10 Marks)
b. Explain the following types of non-destructive methods of inspection, with necessary sketches:
i) X-ray Radiography
ii) Magnetic particle Inspection. (10 Marks)

CBCS SCHEME

USN

--	--	--	--	--	--	--	--	--	--

17ME45B/17MA45

Fourth Semester B.E. Degree Examination, June/July 2019

Machine Tools and Operations

Time: 3 hrs.

Max. Marks: 100

Note: Answer any FIVE full questions, choosing ONE full question from each module.

Module-1

- 1 a. With an illustration explain construction of engine lathe. (10 Marks)
b. Differentiate between the following:
i) Shaper and Planner
ii) Multiple spindle and gang drilling machines. (10 Marks)

OR

- 2 a. With an illustration explain column and knee type milling machine. (10 Marks)
b. Give a broad classification of grinding machines. Explain horizontal spindle reciprocating table surface grinder. (10 Marks)

Module-2

- 3 a. With an illustration explain the following:
i) Thread cutting operation
ii) Horizontal and vertical shaping operations. (10 Marks)
b. Differentiate between the following:
i) Drilling and boring operations
ii) Reaming and milling operations. (10 Marks)

OR

- 4 Explain the following operations:
a) Planning b) Slotting c) Gear cutting d) Grinding e) Turning. (20 Marks)

Module-3

- 5 a. Explain the desirable properties of cutting tool materials. (05 Marks)
b. With an illustration explain geometry of single point cutting tool. (10 Marks)
c. What are cutting fluids and mention its characteristic? (05 Marks)

OR

- 6 a. Define the following: i) Speed ii) Feed iii) Depth of cut. (06 Marks)
b. A brass pin is of 500mm length and 40mm diameter. Find the turning time to reduce the pin to 38.8mm in one pass, when cutting speed is 60 metres/minute and feed is 0.8 mm/min. (06 Marks)
c. Find the time required for taking a complete cut on a plate 600 × 900mm, if the cutting speed is 9 metre/minute. The return time to cutting time ratio is 1:4, and the feed is 3mm. The clearance at each end is 75mm. (08 Marks)

1 of 2

Important Note : 1. On completing your answers, compulsorily draw diagonal cross lines on the remaining blank pages.
2. Any revealing of identification, appeal to evaluator and/or equations written eg, 42+8 = 50, will be treated as malpractice.

Module-4

- 7 a. With an illustration explain orthogonal and oblique cutting process. (10 Marks)
 b. With an illustration explain Merchants circle model for orthogonal cutting process. (10 Marks)

OR

- 8 a. In a orthogonal cutting process following data were observed, chip thickness ratio is 0.4 and rake angle used was 20° and depth of cut 0.5mm. The horizontal and vertical component of cutting forces F_H and F_V where 2000N and 200N respectively. Determine the shear plane angle, chip thickness, angle of friction and resultant cutting force. (10 Marks)
 b. An experiment was conducted on a mild steel tube of 200mm diameter and 3mm thick. An orthogonal cut was taken with a cutting speed of 80mm and 0.15mm per revolution feed with a cutting tool having back rake angle of -10° . It was determined that cutting force = 150N, feed force = 40N. Net horse power for cutting was 3hp and chip thickness was 0.25mm. Calculate the shear strain and strain energy per volume. (10 Marks)

Module-5

- 9 a. Define tool life and explain tool life equation by Taylor relationship between cutting speed and tool life. (10 Marks)
 b. Using Taylorian tool-life equation for machining C-40 steel with 18-4-1 HSS cutting tool at a feed of 0.2mm/rev and depth of cut of 2mm. The following V and T observations have been noted.

V (speed), m/min	25	35
T (Time), min	90	20

Calculate :

- i) n and C in Taylorian equation
 ii) Hence recommend the cutting speed for a desired tool life of 60 minutes. (10 Marks)
- OR**
- 10 a. Discuss the variation of cost elements with cutting speed in a single cut, single pass machining operation. (10 Marks)
 b. Explain the following in connection with machining process:
 i) Tool life for minimum cost
 ii) Minimum production time
 iii) Machining at maximum efficiency. (10 Marks)

* * * * *

USN

--	--	--	--	--	--	--	--	--	--

17ME46B/17MEB406

Fourth Semester B.E. Degree Examination, June/July 2019 Mechanical Measurements and Metrology

Time: 3 hrs.

Max. Marks: 100

Note: Answer any FIVE full questions, choosing ONE full question from each module.

Module-1

- 1 a. What is Metrology? What are the objectives of metrology? (07 Marks)
b. Explain Subdivision of Standards. (08 Marks)
c. Define Wavelength Standard. What are the advantages of wavelength standard? (05 Marks)

OR

- 2 a. Explain the Wringing Phenomena of Slip gauges. (05 Marks)
b. With a neat sketch, explain the working of Sine bar and mention its limitations. (08 Marks)
c. With a neat sketch, explain the working of Auto collimator. (07 Marks)

Module-2

- 3 a. Explain the principle of Interchangeability and Selective assembly. (08 Marks)
b. With neat sketches, explain different types fit. (07 Marks)
c. State and explain Taylor's principle of gauge design. (05 Marks)

OR

- 4 a. Define Comparator. What is the need of a comparator? (05 Marks)
b. With a neat sketch, explain Dial Indicator. What are the advantages? (07 Marks)
c. Sketch and explain the working of LVDT. (08 Marks)

Module-3

- 5 a. With a neat sketch, explain screw thread terminology. (06 Marks)
b. Derive an expression for Best wire size for screw thread measurement. (07 Marks)
c. With a neat sketch, explain the working of Tools maker's microscope. (07 Marks)

OR

- 6 a. With a neat sketch, explain Gear teeth terminology. (06 Marks)
b. With neat sketch, explain the working of laser interferometer. (07 Marks)
c. With a neat sketch, explain the working of co-ordinate measuring machine. (07 Marks)

Module-4

- 7 a. Explain Generalized measurement system, with block diagram. (07 Marks)
b. Define : i) Accuracy ii) Threshold iii) Calibration iv) Hysteresis v) Error. (05 Marks)
c. What is Transducer? Sketch and explain the principle of Electronic Transducer. What are the advantages of Electronic transducers? (08 Marks)

OR

- 8 a. With a circuit diagram, explain Ballast circuit. (08 Marks)
b. With a block diagram, explain Telemetry system. (06 Marks)
c. With a neat sketch, explain stylus type Oscillography. (06 Marks)

Module-5

- 9 a. With a neat sketch, explain working of Prony brake dynamometer. What are its limitations? (10 Marks)
b. With a neat sketch, explain McLeod gauge. (10 Marks)

OR

- 10 a. Define Strain gauge. With a neat sketch, explain wheat stone bridge circuit. (10 Marks)
b. Define Thermocouple. State the law's of thermocouple and explain. (06 Marks)
c. Write a note on :
i) Thermo couple materials ii) Advantages and disadvantages of thermocouples . (04 Marks)

* * * * *

CBCS SCHEME

USN

--	--	--	--	--	--	--	--	--	--

15ME42

Fourth Semester B.E. Degree Examination, June/July 2019 Kinematics of Machines

Time: 3 hrs.

Max. Marks: 80

Note: Answer any FIVE full questions, choosing ONE full question from each module.

Module-1

- 1 a. Define: i) Kinematic chain ii) Mechanism
iii) Machine iv) Degree of freedom (08 Marks)
b. Sketch and explain crank and slotted lever mechanism. (08 Marks)

OR

- 2 a. Explain Peaucelliers' exact straight line mechanism with a line diagram. (06 Marks)
b. Derive the expression for necessary condition of correct steering. Explain with a neat sketch, the Ackerman steering gear mechanism. (10 Marks)

Module-2

- 3 A four bar mechanism ABCD is made up of four links, pin jointed at the ends. AD is a fixed link which is 180 mm long. the links AB, BC and CD are 90 mm, 120 mm and 120 mm long respectively. At certain instant, the link AB makes an angle of 60° with the link AD. If the link AB rotates at a uniform speed of 100 rpm clockwise, determine, (i) Angular velocity of the links BC and CD, (ii) Angular acceleration of the links CD and CB. Solve by relative method. (16 Marks)

OR

- 4 a. State and prove Kennedy's theorem. (06 Marks)
b. Determine the velocity and acceleration of the piston by Klein's construction to the following specifications of a single slider crank mechanism.
Stroke = 300 mm
Ratio of length of connecting rod to crank length = 4
Speed of the engine = 300 rpm
Position of crank = 45° with inner dead center. (10 Marks)

Module-3

- 5 a. State loop-closure equation and explain in brief. (04 Marks)
b. In a reciprocating engine, the length of the crank is 250 mm and length of connecting rod is 1000 mm. The crank rotates at a uniform speed of 300 rpm clockwise. Crank is at 30° from inner dead center. Determine:
i) Velocity of piston and angular velocity of connecting rod
ii) Acceleration of piston and angular acceleration of connecting rod by complex algebra method from first principle. (12 Marks)

OR

- 6 a. Derive the Freudenstein's equation for four bar mechanism. (10 Marks)
b. Explain function generation in four bar mechanism. (06 Marks)

Module-4

- 7 a. Derive an expression for path of contact for two meshing spur gears having involute profile. (08 Marks)
- b. A pair of spur gears has 16 teeth and 18 teeth, a module 12.5mm, an addendum 12.5 mm and a pressure angle 14.5 degrees. Prove that the gears have interference. Determine the minimum number of teeth and the velocity ratio to avoid the interference. (08 Marks)

OR

- 8 An epicyclic gear train as shown in Fig. Q8 consists of a sunwheel(S), a stationary internal gear (E) and three identical planet wheels (P) carried on a star shaped planet carrier(C). The size of different toothed wheels are such that the planet carrier C rotates at $\left(\frac{1}{5}\right)$ of the speed of the sun wheel. The minimum number of teeth on any wheel is 16. The driving torque on the sun wheel is 100 Nm. Determine:
- Number of teeth on different wheels of train
 - Torque necessary to keep the internal gear stationary.

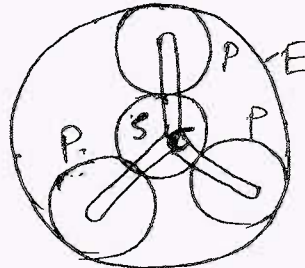

Fig. Q8

(16 Marks)

Module-5

- 9 A roller follower is raised through a distance of 35 mm in 120° rotation of the cam, remains at rest for the next 30° and is lowered during further 120° rotation of cam, The raising of the follower takes place with cycloidal motion and the lowering with uniform acceleration retardation motion. However the uniform acceleration period is 2/3 of the uniform retardation period. The least radius of the cam is 25 mm and the roller radius is 10 mm. Draw the cam profile. Also determine the maximum velocity and acceleration during rise and return. Speed of the cam is 200 rpm and rotates in clockwise direction. (16 Marks)

OR

- 10 A symmetrical circular arc cam operating a flat faced follower has the following particulars. Least radius of the cam is 30 mm, lift is 20 mm, angle of lift is 75°, nose radius is 5 mm, speed is 600 rpm; find:
- The principal dimensions of the cam
 - The acceleration of the follower at the beginning of lift, at the end of contact with the circular flank, at the beginning of contact with nose and at the apex of nose. (16 Marks)

CBCS SCHEME

USN

--	--	--	--	--	--	--	--	--	--

15ME43

Fourth Semester B.E. Degree Examination, June/July 2019

Applied Thermodynamics

Time: 3 hrs.

Max. Marks: 80

Note: 1. Answer any FIVE full questions, choosing ONE full question from each module.

2. Use of Thermodynamic Data handbook / Steam tables / Mollier chart are permitted.

Module-1

- 1 a. What is an Air Standard efficiency? Derive an expression for Air Standard efficiency of a Diesel cycle. (08 Marks)
- b. An engine of 250mm bore and 375mm stroke works on Otto cycle. The clearance volume is 0.00263m^3 . The initial pressure and temperature are 1 bar and 50°C . If the maximum pressure is limited to 25 bar, find the following. i) The air standard efficiency of cycle
ii) The mean effective pressure for the cycle. (08 Marks)

OR

- 2 a. Discuss briefly any two methods employed for improvement of thermal efficiency of open cycle gas turbine plant. (06 Marks)
- b. State the working difference between Turbo Jet and Turbo-prop engines. (04 Marks)
- c. A gas turbine has a pressure ratio of 6 and a maximum cycle temperature of 600°C . The Isentropic efficiencies of compressor and turbine are 0.82 and 0.85 respectively. Calculate the power output in kilowatts of an electric generator geared to the turbine when the air enters the compressor at 15°C at the rate of 15 kgs. Take $C_p = 1.005\text{ kJ/kg K}$ and $\gamma = 1.4$ for compression process and $C_p = 1.11\text{ kJ/kg K}$ and $\gamma = 1.333$ for the expansion process. (06 Marks)

Module-2

- 3 a. Describe the different processes of Rankine cycle. Derive also an expression for its efficiency. (08 Marks)
- b. A simple Rankine cycle works between 28 bar and 0.06 bar, the initial condition of steam is being dry saturated. Calculate the cycle efficiency, work ratio and specific steam consumption. (08 Marks)

OR

- 4 a. Explain with the help of neat T-S diagram and block diagram a practical regenerative cycle and also derive an expression for its thermal efficiency with one open feed water heater. (08 Marks)
- b. A turbine is supplied with steam at a pressure of 32 bar and a temperature of 410°C . If the steam is reheated at 5.5 bar to a temperature of 395°C and then expanded isentropically to a pressure of 0.08 bar, what will be the dryness fraction at the exit of turbine and thermal efficiency of the cycle? (08 Marks)

Module-3

- 5 a. Define the following: i) Stoichiometric air fuel Ratio ii) Excess air iii) Enthalpy of Reaction iv) Enthalpy of Formation. (08 Marks)
- b. The following is the volumetric analysis of the dry exhaust from an I.C. Engine $\text{CO}_2 = 8.9\%$, $\text{CO} = 8.2\%$, $\text{H}_2 = 4.3\%$, $\text{CH}_4 = 0.5\%$, $\text{N}_2 = 78.1\%$. If the Fuel used is Octane C_8H_{18} . Determine the air Fuel Ratio on mass basis. (08 Marks)

1 of 2

Important Note: 1. On completing your answers, compulsorily draw diagonal cross lines on the remaining blank pages.
2. Any revealing of identification, appeal to evaluator and/or equations written eg. 42+8 = 50, will be treated as malpractice.

OR

- 6 a. Explain the phenomenon of knocking in SI engine. What are the different factors which influence the knocking? (08 Marks)
- b. During a 60 minute trial of a single cylinder four stroke engine the following observations were recorded. Bore = 0.3m , Stroke = 0.45m , Fuel consumption = 11.4kg , Calorific value = 42000 kJ/kg , IMEP = 6 bar , Net load on brake = 1500N , Speed = 300 rpm , Brake drum diameter = 1.8m , Rope diameter = 20mm , Quantity of Jacket cooling water = 600kg , Rise in temperature of Jacket cooling water = 55⁰C, Quantity of air = 250 kg Exhaust gas temperature = 420⁰C , Ambient temperature = 20⁰C , C_p for gases = 1kJ/kg K. Find IP, BP, mechanical efficiency and draw heat balance sheet on minute basis. (08 Marks)

Module-4

- 7 a. Discuss the effect of following on the performance of a vapour compression system :
i) Effect on suction pressure ii) Effect of super heating iii) Effect of subcooling. (08 Marks)
- b. A refrigeration system of 10.5 tonnes capacity at an evaporator temperature of -12⁰C and a condenser temperature of 27⁰C is needed in a food storage locker. The Refrigerant Ammonia is sub cooled by 6⁰C before entering the expansion valve. The vapour is 0.95 dry as it leaves the evaporator coil. Find C.O.P and power required in KW. (08 Marks)

OR

- 8 a. Define Specific humidity and derive an expression for the specific humidity. (08 Marks)
- b. It is required to design an air conditioning plant for a small office for following conditions : Outdoor condition = 14⁰C DBT and 10⁰C WBT , Required conditions = 20⁰C DBT and 60% RH ; Amount of air circulated = 0.3m³/min/person , Seating capacity = 60. The required condition is achieved first by heating and then by adiabatic humidifying. Determine i) Heating capacity of coil in KW and its surface temperature if the by pass factor of coil is 0.4 ii) Capacity of the humidifier. (08 Marks)

Module-5

- 9 a. Define volumetric efficiency of an air compressor and derive an expression for volumetric efficiency. (08 Marks)
- b. An air compressor takes in air at 1 bar and 20⁰C and compresses it according to law $PV^{1.2} = \text{constant}$. It is then delivered to a receiver at a constant pressure of 10 bar. Determine i) Temperature at the end of compression ii) Work done iii) Heat transferred during the compression per kg of air. (08 Marks)

OR

- 10 a. What is the effect of friction on the flow through a steam nozzle? Explain with the help of h – s diagram. (08 Marks)
- b. Steam is expanded in a set of nozzles from 10 bar 200⁰C to 5 bar. Neglecting the initial velocity, find the minimum area of the nozzle required to allow a flow of 3kg/s under the given conditions. Assume that expansion of steam to be isentropic. (08 Marks)

* * * * *

USN

--	--	--	--	--	--	--	--	--	--

15ME44

Fourth Semester B.E. Degree Examination, June/July 2019 Fluid Mechanics

Time: 3 hrs.

Max. Marks: 80

Note: Answer any FIVE full questions, choosing ONE full question from each module.

Module-1

- 1 a. Define the following terms:
- | | | |
|------------------|-----------------------|------------|
| i) Mass density | ii) Dynamic viscosity | |
| iii) Capillarity | iv) Surface tension | (04 Marks) |
- b. State and prove Pascal's law. (06 Marks)
- c. A steel shaft of 30 mm diameter rotates at 240 rpm, in a bearing of diameter 32 mm. Lubricant oils of viscosity 5 poise used for lubrication of shaft in the bearing. Determine the torque required at the shaft and power lost in maintaining the lubrication. Length of bearing is 90 mm. (06 Marks)

OR

- 2 a. Derive an expression for total pressure force and position of centre of pressure for a vertical surface submerged in water. (08 Marks)
- b. A cylindrical buoy is 2m in diameter 2.5 m long and weighs 2.2 metric tonnes. The density of sea water is 1025 kg/m³. Show that the body cannot float with its axis vertical. (08 Marks)

Module-2

- 3 a. Distinguish between:
- | | |
|--------------------------------|------------|
| i) Steady and unsteady flow | |
| ii) Laminar and turbulent flow | (04 Marks) |
- b. Derive the continuity equation in three dimensional Cartesian coordinates for a steady incompressible flow. (06 Marks)
- c. A stream function for a 2D flow is given by $\psi = 8xy$. Calculate the velocity at a point P(4, 5). Find also the velocity potential function ϕ . (06 Marks)

OR

- 4 a. Derive the Euler's equation for ideal fluids and hence deduce Bernoulli's equation of motion. Mention the assumptions made. (10 Marks)
- b. A rectangular channel 2m wide has a discharge of 0.25 m³/s which is measured by a right angled V-Notch. Find the position of the apex of the notch from the bed of the channel, if maximum depth of water is not to exceed 1.3 m. Take $C_d = 0.62$. (06 Marks)

Module-3

- 5 a. Derive Hagen-Poiseuille equation for viscous flow through a circular pipe. (10 Marks)
- b. Determine: (i) The pressure gradient along flow, (ii) The average velocity, (iii) The discharge for an oil of viscosity 0.02 N-S/m² flowing between two stationary parallel plates 1 m wide maintained 10 mm apart. The velocity midway between the plates is 2 m/s. (06 Marks)

Important Note : 1. On completing your answers, compulsorily draw diagonal cross lines on the remaining blank pages.
2. Any revealing of identification, appeal to evaluator and/or equations written eg, 42+8 = 50, will be treated as malpractice.

OR

- 6 a. Derive the Darcy-Weisbach equation for the loss of head due to friction in a pipe. (08 Marks)
 b. The diameter of a horizontal pipe which is 300 mm is suddenly enlarged to 600 mm. The rate of flow of water through this pipe is $0.4 \text{ m}^3/\text{s}$. If the intensity of pressure in the smaller pipe is 125 kPa. Determine:
 i) Loss of head due to sudden enlargement
 ii) Intensity of pressure in the larger pipe
 iii) Power lost due to enlargement. (08 Marks)

Module-4

- 7 a. Define the following and write their equations:
 i) Drag
 ii) Lift
 iii) Displacement thickness
 iv) Momentum thickness. (08 Marks)
 b. On a flat plate of 2m length and 1m width experiments were conducted in a wind tunnel with a wind speed of 50 km/hr, the plate is kept at such an angle that the coefficient of drag and lift are 0.18 and 0.9 respectively. Determine:
 i) Drag force
 ii) Lift force
 iii) Resultant force
 iv) Power exerted by the air stream on the plate.
 Take density of air = 1.15 kg/m^3 . (08 Marks)

OR

- 8 a. Define the following dimensionless numbers with equation:
 i) Reynold's number
 ii) Froude's number
 iii) Euler's number
 iv) Webber's number (08 Marks)
 b. Torque developed by a disc of diameter D , rotating at a speed N is dependent on fluid viscosity μ and fluid density ρ . Obtain an expression for torque, $T = \rho N^2 D^5 \phi \left[\frac{\mu}{\rho N D^2} \right]$ using Buckingham's π - theorem. (08 Marks)

Module-5

- 9 a. Define the following:
 i) Mach number
 ii) Mach angle
 iii) Mach cone
 iv) Subsonic flow
 v) Supersonic flow (10 Marks)
 b. A projectile travels in air of pressure 100 kPa at 10°C at a speed of 1500 km/hr. Find the mach number and the mach angle. Take $K = 1.4$ and $R = 287 \text{ J/kg}^\circ\text{K}$. (06 Marks)

OR

- 10 a. Mention the applications and limitations of CFD (Computational Fluid Dynamics). (08 Marks)
 b. Define the following terms and write the relevant equations for the same:
 i) Stagnation temperature
 ii) Stagnation pressure (08 Marks)

* * * * *

USN

--	--	--	--	--	--	--	--	--	--

15ME45A

Fourth Semester B.E. Degree Examination, June/July 2019 Metal Casting and Welding

Time: 3 hrs.

Max. Marks: 80

Note: Answer any FIVE full questions, choosing ONE full question from each module.

Module-1

- 1 a. Define casting. With a neat sketch explain briefly the steps involved in making a sand casting. (08 Marks)
b. List the different types of patterns used in sand molding. Explain with neat sketches any three patterns. (08 Marks)

OR

- 2 a. What are the different types of molding sands? Also discuss about the desirable properties of molding sand. (08 Marks)
b. With neat sketches explain the steps involved in shell molding process. What are its advantages and limitations? (08 Marks)

Module-2

- 3 a. With a neat sketch explain the construction and working of a Cupola furnace. What are its advantages? (10 Marks)
b. With a neat sketch explain the constructional features and working of direct arc electric furnace. (06 Marks)

OR

- 4 a. With a neat sketch explain continuous casting process. Mention its merits and demerits. (08 Marks)
b. What is die casting? With a neat and labeled sketch, explain cold chamber die casting process. (08 Marks)

Module-3

- 5 a. What is degassing? With neat sketches explain two types of vacuum degasification methods. (08 Marks)
b. Define nucleation. Explain the different types of nucleation with neat sketches. (08 Marks)

OR

- 6 a. Explain the basic steps involved in cleaning and finishing of castings. (04 Marks)
b. Write a note on various types of casting defects. What are its causes and remedies? (06 Marks)
c. With a neat sketch, explain the principle of stir casting process. (06 Marks)

Module-4

- 7 a. Sketch and explain MIG welding process. Mention its advantages and disadvantages. (08 Marks)
b. Explain with a neat sketch submerged arc welding process. What are its advantages? (08 Marks)

Important Note : 1. On completing your answers, compulsorily draw diagonal cross lines on the remaining blank pages.
2. Any revealing of identification, appeal to evaluator and /or equations written eg. 42+8 = 50, will be treated as malpractice.

OR

- 8 a. With a neat sketch explain the electron beam welding process. What are its advantages? (08 Marks)
b. Sketch and explain the thermit welding process. What are its advantages and applications? (08 Marks)

Module-5

- 9 a. What is Heat Affected Zone (HAZ)? Explain the parameters affecting HAZ. (08 Marks)
b. Write short notes on :
(i) Electrodes used in welding
(ii) Welding defects. (08 Marks)

OR

- 10 a. Compare Soldering and Brazing process. Mention their advantages, limitations and applications. (08 Marks)
b. With a neat sketch, explain the Oxy-acetylene gas welding process. What are its advantages and disadvantages? (08 Marks)

* * * * *

USN

--	--	--	--	--	--	--	--	--	--

15ME45B

Fourth Semester B.E. Degree Examination, June/July 2019 Machine Tools and Operations

Time: 3 hrs.

Max. Marks: 80

Note: Answer any FIVE full questions, choosing ONE full question from each module.

Module-1

- 1 a. With a neat sketch, explain principal parts of engine lathe. (12 Marks)
- b. Write any four important differences between Engine lathe, Capstan lathe and Turret lathe. (04 Marks)

OR

- 2 a. With a neat sketch explain a radial drilling machine. (08 Marks)
- b. Explain with neat sketch hydraulic drive Quick return mechanism. (08 Marks)

Module-2

- 3 a. With a neat sketch explain types of motion for turning, shaping, planning, slotting and drilling operations. (10 Marks)
- b. With respect to lathe machine tool, define following machining parameters:
(i) Cutting speed (ii) Feed (iii) Depth of cut. (03 Marks)
- c. Index 69 divisions by compound indexing on periphery of a circular blank, the index plate with circles of holes – 21, 23, 27, 29, 31, 33 is available. (03 Marks)

OR

- 4 a. With a neat sketch explain the following operations:
(i) Plain Milling
(ii) Form Milling
(iii) Centreless Grinding
(iv) Reaming
(v) Horizontal shaping. (10 Marks)
- b. Estimate the machining time required to machine 5mm thick layer from a workpiece of 200mm wide × 400mm (length) × 50mm (thick) MS material. The available stroke rate are 10, 20, 40, and 80 stroke per minute. The feed is 0.28 mm/stroke. The depth of cut was given as 1mm during each cut. Consider the cutting speed 30 m/min. Also determine the MRR, [Assume R or $m = 2/3 = \frac{RT}{CT}$]. (06 Marks)

Module-3

- 5 a. Explain the desirable properties of cutting tool material. (06 Marks)
- b. Explain the following cutting tool material with respect to usage, composition and structure
(i) High speed steel (ii) Ceramics. (10 Marks)

OR

- 6 a. Sketch and explain the nomenclature of a single point cutting oil. (10 Marks)
- b. Explain the desirable properties and purpose of cutting fluids. (06 Marks)

Important Note : 1. On completing your answers, compulsorily draw diagonal cross lines on the remaining blank pages.
2. Any revealing of identification, appeal to evaluator and /or equations written eg. 42+8 = 50, will be treated as malpractice.

Module-4

- 7 a. Write the difference between orthogonal cutting and oblique cutting (any 6 points). (06 Marks)
- b. Explain Merchants circle diagram and derive the equation for the co-efficient of friction between tool face and chip. (10 Marks)

OR

- 8 a. In an orthogonal cutting process, the following data were obtained :
Chip length obtained = 96mm, uncut chip length = 240mm, Rake angle used = 20° , Depth of cut = 0.6 mm, Horizontal component of cutting force = 2400 N and vertical component of cutting force = 240 N. Calculate (i) Shear plane angle (ii) Resultant cutting force for the given data. (08 Marks)
- b. Derive an expression for shear angle in orthogonal cutting in terms of rake angle and chip thickness ratio. (04 Marks)
- c. With a neat sketch explain different types of chips produced during machining process. (04 Marks)

Module-5

- 9 a. What is tool life? Explain the effect of cutting parameters on tool life. (06 Marks)
- b. The tool life for a HSS tool is expressed by the relation $VT^{1.7} = C_1$ and for the tungsten carbide $VT^{1.5} = C_2$. If the tool life for cutting speed of 24 m/min is 128 min, compare the life of the two tools at a speed of 30 m/min. (06 Marks)
- c. Define Machinability and Machinability Index. (04 Marks)

OR

- 10 a. The tool Taylor tool life equation for carbide tool steel work piece pair was obtained experimentally : $VT^{0.25} = 650$ where V is 271 m/min and T is in min. A batch of 1000 steel parts., each 100mm in diameter and 250mm in length is to be rough turned using a feed of 0.2 mm/rev. If the cost per cutting edge of throw away carbide insert is Rs. 50 , time required to reset the cutting edge is 1 min, and the total machined rate (including operator cost) is Rs. 300/hr. Calculate
(i) Optimum cutting speed for minimum cost
(ii) Corresponding tool life
(iii) Total production time for the given batch (06 Marks)
- b. Explain different forms of tool wear and various tool wear mechanisms. (10 Marks)

* * * * *

USN

--	--	--	--	--	--	--	--	--	--

15ME46B/15MEB406

Fourth Semester B.E. Degree Examination, June/July 2019

Mechanical Measurements and Metrology

Time: 3 hrs.

Max. Marks: 80

Note: Answer any FIVE full questions, choosing ONE full question from each module.

Module-1

- 1 a. Describe with a suitable sketch Imperial Standard Yard. (06 Marks)
- b. Explain with a neat sketch, the use of sine bar for measurement of known angle. (06 Marks)
- c. Build up the slip gauge combination using the M112 set for the following:
 - (i) 52.9875 mm
 - (ii) 35.357 mm

M112 SET

Range	Steps	Pieces
1.0005	-	1
1.001 to 1.009	0.001	9
1.01 to 1.49	0.01	49
0.5 to 24.5	0.5	49
25, 50, 75, 100	25.0	4

(04 Marks)

OR

- 2 a. Explain briefly the wringing phenomenon in slip gauges. (06 Marks)
- b. List some of the advantages of wavelength standards. (04 Marks)
- c. Explain the principle of an autocollimator and list some of its applications. (06 Marks)

Module-2

- 3 a. Explain the different types of fits with suitable sketches. (06 Marks)
- b. Define a comparator. With a neat sketch explain Solex pneumatic gauge. (06 Marks)
- c. Determine the dimensions of hole and shaft assembly designated as 100 H₈e₉, fit given:

100 mm lies in the diameter step of 80 and 120 mm.

$$i = 0.45 (D)^{1/3} + 0.001D, \text{ (D in mm, } i \text{ value in microns)}$$

$$IT8 = 25i$$

$$IT9 = 40i$$

Fundamental deviation of 'e' shaft is given by $-5.5D^{0.41}$ in microns. Also determine the maximum and minimum clearances. (04 Marks)

OR

- 4 a. Distinguish between the following:
 - i) Hole Basis System and Shaft basis system (08 Marks)
 - ii) Geometric Tolerances and Positional tolerances (02 Marks)
- b. State Taylor's principle on limit gauges. (06 Marks)
- c. Sketch and explain Johansson's Mikrokator. (06 Marks)

Important Note : 1. On completing your answers, compulsorily draw diagonal cross lines on the remaining blank pages.
2. Any revealing of identification, appeal to evaluator and /or equations written eg. 42+8 = 50, will be treated as malpractice.

Module-3

- 5 a. With a neat sketch explain the Three-Wire method for measurement of effective diameter. (05 Marks)
 b. With a neat sketch, explain Tool Maker's microscope. (06 Marks)
 c. Explain with a neat sketch the use of Gear Tooth Vernier Calipers for the measurement of Chordal thickness of a spur gear. (05 Marks)

OR

- 6 a. Explain any one type of laser Interferometer. List some of the advantages of lasers. (08 Marks)
 b. With a neat sketch, explain CMM. List some of the applications of CMM. (08 Marks)

Module-4

- 7 a. Describe the generalized measurement system with a block diagram. (06 Marks)
 b. Define the following terms:
 (i) Accuracy (ii) Precision (iii) Hysteresis
 (iv) Sensitivity (v) Loading effects (05 Marks)
 c. Sketch and explain any one type of electrical transducer. (05 Marks)

OR

- 8 a. Explain the inherent problems present in mechanical modifying system. (05 Marks)
 b. Describe the Cathode-Ray-Oscilloscope with a neat sketch. (07 Marks)
 c. With a neat sketch, explain any one type of capacitive transducer. (04 Marks)

Module-5

- 9 a. Explain with a neat sketch, McLeod gauge for measurement of low pressure. (08 Marks)
 b. With a neat sketch, explain the working principle of Prony Brake Dynamometer. (08 Marks)

OR

- 10 a. State the laws of thermocouples. (04 Marks)
 b. Explain the construction and working principle of optical pyrometer. (08 Marks)
 c. Write a brief note on Gauge factor with respect to the strain gauges. (04 Marks)

* * * * *

--	--	--	--	--	--	--	--	--	--

Fourth Semester B.E. Degree Examination, June/July 2019

Applied Thermodynamics

Time: 3 hrs.

Max. Marks: 100

- Note: 1. Answer any FIVE full questions, selecting at least TWO questions from each part.**
2. Use of Steam table and thermodynamic data hand books are allowed.

PART – A

- 1 a. Define the following:
 - i) Excess air
 - ii) Enthalpy of formation
 - iii) Enthalpy of combustion
 - iv) Higher calorific value and lower calorific value
 - v) Combustion efficiency (10 Marks)
- b. In an engine test, the dry volumetric analysis of the products are $\text{CO}_2 = 5.27\%$, $\text{O}_2 = 13.38\%$ and $\text{N}_2 = 81.35\%$. Assuming that the fuel is a pure hydro carbon and that it is completely burnt, estimate the percentage of carbon and hydrogen in the fuel by mass and the air fuel ratio by mass. (10 Marks)

- 2 a. Derive an expression for air standard efficiency of constant pressure cycle stating the assumptions made. (10 Marks)
- b. An engine works on a limited pressure cycle with pressure and temperature before the beginning of adiabatic compression is 102 kPa and 27°C. Heat added during constant volume process is 232 kJ/kg, where as heat added during constant pressure process is 3.2% of the expansion stroke. If the compression ratio is 16, $\gamma = 1.4$ and $C_p = 1.005$. find:
 - i) Pressure and temperature at end of compression
 - ii) Pressure and temperature at end of constant volume heat addition
 - iii) Temperature before beginning of expansion
 - iv) Heat added during constant pressure. (10 Marks)

- 3 a. Define the following:
 - i) BSFC
 - ii) Indicated thermal efficiency
 - iii) Relative efficiency (06 Marks)
- b. What do you mean by heat balance sheet? Explain on percentage basis. (04 Marks)
- c. A trial is carried out on 4-S single cylinder oil engine working on Otto cycle gave the following results duration of trial is one hour. Bore = 18 cms, stroke length = 36 cms, clearance volume = 1830 cc, speed = 280 rpm, area of indicator diagram = 4.25 cm², length of indicator diagram = 6.25 cms, spring scale = 1000 kPa/cm, load on brake drum = 600 N, dia of brake drum = 1 mtr, dia of rope = 0.2 mtr, volume of fuel = 4.25 ltr, specific gravity of fuel = 0.8, calorific value of fuel = 43,000 kJ/kg, mass of water = 420 kg, rise in temperature of water = 27°C, air fuel ratio = 34:1, temperature of gas = 410°C, $C_{p_g} = 1.005$ kJ/kg°K, find:
 - i) Mechanical efficiency
 - ii) Indicated thermal efficiency
 - iii) Air standard efficiency
 - iv) Heat balance sheet (10 Marks)

- 4 a. With T-S diagram, explain the effect on Rankine cycle by decreasing condenser pressure and increasing boiler pressure. (04 Marks)
- b. Explain the working of a regenerative Rankine cycle for one feed water heater with line and T-S diagram. (06 Marks)
- c. In a regenerative vapour cycle with open feed water heater steam enters turbine at 90 bar and 350°C and expands to 9 bar where a part of steam is extracted and passed to the open feed water heater. The remaining steam expands in a turbine upto 0.1 bar. If net output of the cycle is 120 MW, find (i) Thermal efficiency (ii) Mass flow rate. (10 Marks)

PART – B

- 5 a. Find the optimum pressure ratio for minimum power of a multi stage reciprocating compressor. What are the assumptions made? (10 Marks)
- b. A single acting two stage air compressor deals with 4 m³/min of air at 1 bar and 15°C with a speed of 250 rpm. The delivery pressure is 80 bar. Assuming perfect inter cooling, find the minimum power required by the compressor, bore, stroke of the compressor. Assume the piston speed is 3 m/s. Take mechanical efficiency 75% and volumetric efficiency 80% per stage. Assume $n = 1.25$ for both stages neglect the clearance. (10 Marks)
- 6 a. With line diagram and T-S diagram, explain intercooler and reheat methods to improve the efficiency of a gas turbine. (06 Marks)
- b. With a neat sketch, explain Rocket propulsion. (05 Marks)
- c. Find the required A:F ratio in a gas turbine where the efficiency of turbine and compressor are 85% and 80% respectively. Air enters the compressor at 1 bar and 27°C and maximum cycle temperature is 875°C. The pressure ratio is 4. Take the calorific value of fuel 42000 kJ/kg. There is a loss of 10% of calorific value in the combustion chamber. (09 Marks)
- 7 a. What are the desirable properties of a good refrigerant? (04 Marks)
- b. With p-h and T-S diagram explain effects of evaporator pressure, condenser pressure. (06 Marks)
- c. An ammonia refrigerator operates between -16°C and 50°C respectively. The vapour is dry saturated at the inlet of compressor, calculate:
- The refrigerator effect
 - Power/KW cooling effect
 - COP
 - Mass of refrigerant/KW cooling

Take C_p for NH₃ as 3 kJ/kg°K. The properties NH₃ are

Temperature	h_f	h_g	S_g
-16°C	-	1424.4	5.56
50°C	421.7	1437.1	4.7696

(10 Marks)

- 8 a. With a diagram, explain psychrometric chart. (05 Marks)
- b. With neat sketches, explain summer air conditioning and winter air conditioning. (06 Marks)
- c. In a room the DBT is 35°C and WBT = 25°C, calculate:
- Specific humidity
 - Relative humidity
 - Vapour density
 - Enthalpy of mixture without psychrometric chart. (09 Marks)

* * * * *

--	--	--	--	--	--	--	--	--	--

Fourth Semester B.E. Degree Examination, June/July 2019
Fluid Mechanics

Time: 3 hrs.

Max. Marks: 100

Note: Answer any FIVE full questions, selecting at least TWO full questions from each part.

PART – A

1.
 - a. What is fluid? How do you classify them? (05 Marks)
 - b. Explain in detail the vapour pressure and cavitation. (04 Marks)
 - c. Write or derive the relationship between bulk modulus and pressure for a gas during adiabatic process. (03 Marks)
 - d. Calculate the dynamic viscosity of an oil, which is used for lubrication between a square plate of size $0.8\text{m} \times 0.8\text{m}$ and inclined plane with angle 30° with horizontal. The weight of the plate is 300N and slides down on inclined plane with a uniform velocity of 0.3m/sec the thickness of oil film is 1.5mm . (08 Marks)

2.
 - a. With the help of Inverted-U-tube manometer differential. Derive expression for pressure difference. (05 Marks)
 - b. Derive an expression for depth of centre of pressure from free surface of liquid of plane surface submerged in the liquid and inclined at angle ' θ ' to free surface. (08 Marks)
 - c. A cylinder 3m diameter and 4m long retains water on one side. The cylinder is supported as shown in Fig.Q.2(c). Determine the horizontal reaction at 'A' and the vertical reaction at 'B'. The cylinder weights 196 kN (Ignore friction). (07 Marks)

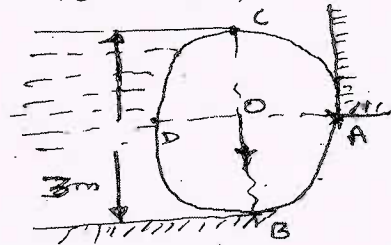

Fig.Q.2(c)

3.
 - a. Derive an expression for determination of metacentric height theoretically. (08 Marks)
 - b. Define with equations velocity potential and stream functions. (04 Marks)
 - c. A fluid flow field is given by $V = x^2yi + y^2zj - (2xyz + yz^2)k$. Prove that it is a possible steady incompressible fluid-flow. Calculate acceleration at the point $(2, 1, 3)$. (08 Marks)

4.
 - a. While considering the equations of motion what are the forces present? (03 Marks)
 - b. Write the Euler's equation of motion. Reduce it to Bernoulli's equation and state the Bernoulli's statement. (07 Marks)
 - c. A pump has a tapering pipe running full of water the pipe is placed vertically with the diameter at the base and top being 1.2m and 0.6m respectively. The pressure at the upper end is 240mm of Hg vacuum. While lower end is 15kPa . Assume head loss to be 20% of difference of velocity head. Calculate the discharge, the flow is vertically up-wards and the difference of elevation is 3.9m . (10 Marks)

PART – B

- 5 a. What is Pitot-tube? Write its velocity expression. (03 Marks)
 b. With sketch, derive an expression for rate of flow or discharge through-ORIFICEMETER. (07 Marks)
 c. Derive on the basis of dimensional analysis suitable parameters to present the thrust developed by a propeller. Assume that the thrust 'P' depends upon angular velocity ω , Speed of advance V, Diameter D, Dynamic viscosity μ , Mass density ρ , Elasticity of the fluid medium which can be denoted by the speed of sound in the medium C. (10 Marks)
- 6 a. With expressions discuss various minor losses. (08 Marks)
 b. Determine the difference in the elevations between the water surfaces in the two tanks which are connected by a horizontal pipe of diameter 300mm and length 400m. The rate of flow of water through the pipe is 300 litres/sec. Consider all losses and take this value of $f = 0.008$ and also draw the HGL and TEL (Hydraulic and Total energy line). (12 Marks)
- 7 a. Derive an expression for drop in pressure head for a given length of two parallel stationary plates. (12 Marks)
 b. An oil of viscosity 0.1 N-s/m^2 and relative density 0.9 flowing through a circular pipe of diameter 50mm and length 300m. The rate of flow of fluid through the pipe is 3.5 litres/sec. Find the drop in pressure for a length of pipe 300m and also the shear-stress at the pipe wall. (08 Marks)
- 8 a. Derive an expression for displacement thickness and energy thickness. (10 Marks)
 b. Explain propagation of pressure waves in a compressible fluid. (05 Marks)
 c. Find the velocity of a bullet fired in air if the mach angle is 30° . Take $R = 0.287 \text{ kJ/kg}^\circ\text{K}$, $\gamma = 1.4$ for air assume temperature as 15°C . (05 Marks)

* * * * *

--	--	--	--	--	--	--	--	--	--

Fourth Semester B.E. Degree Examination, Dec.2018/Jan.2019

Kinematics of Machines

Time: 3 hrs.

Max. Marks: 80

Note: Answer any FIVE full questions, choosing ONE full question from each module.

Module-1

- 1 a. Explain with neat sketch the mechanism required to convert rotary motion to reciprocating motion [which should have only one turning pair] (08 Marks)
- b. State and explain the suitable mechanism which can be used in Forming machines/sheet metal punching. (08 Marks)

OR

- 2 a. Some of the 4 bar linkages are shown in Fig Q2(a) where the number indicate the respective link in Lengths in 'cm'. Identify the nature of each mechanism whether
 - (i) double crank
 - (ii) crank rocker
 - (iii) Double Rocker. Give Reason in brief (12 Marks)

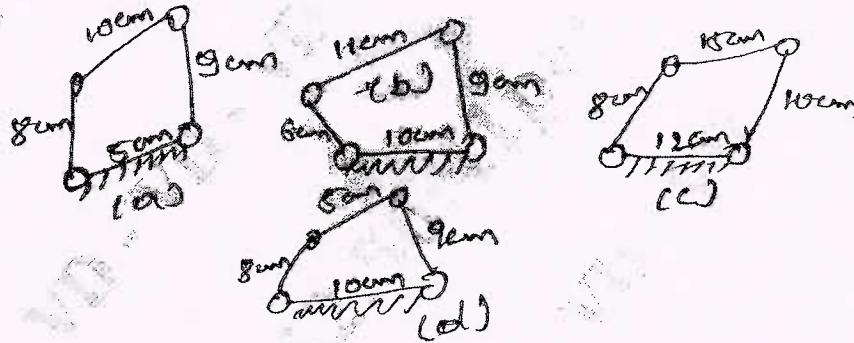

Fig Q2(a)

- b. Differentiate between
 - i) Machine and mechanism
 - ii) Binary joints and binary links (04 Marks)

Module-2

- 3 In the mechanism shown in Fig Q3 crank 2 rotates out 300 rpm. Find the acceleration of point C in magnitude, direction and sense. Find also the angular acceleration of link 3.

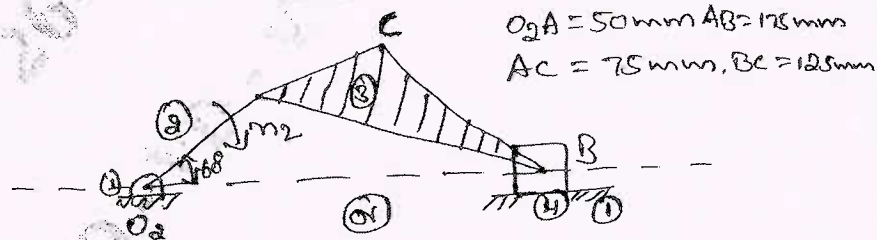

Fig Q3

(16 Marks)

OR

- 4 A pin jointed 4 bar mechanism ABCD show Fig Q4. Link AB = 150mm, BC = 180mm, CD = 180mm and fixed link AD = 300mm. Link AB makes 60° with link AD, and rotates uniformly at 100 rpm. Locate all the instantaneous centres and find the angular velocity of link BC and linear velocity of link CD.

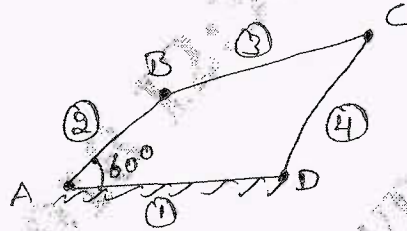

Fig Q4

(16 Marks)

Module-3

- 5 Develop an equation for the relationship between the Angular velocities of the input crank and output crank of 4 bar linkage shown in Fig Q5. Using loop closure equation.

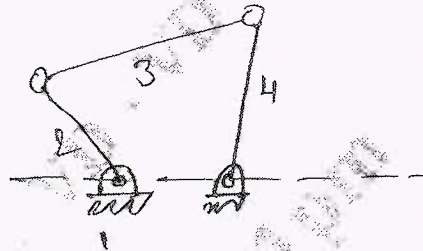

Fig Q5

(16 Marks)

OR

- 6 Design a four bar mechanism when the motions of the input and output links are governed by a function $y = 2x^2$ and x varies 2 to 4 with an interval of 1. Assume θ to vary from 40° to 120° and ϕ from 60° to 132° .

(16 Marks)

Module-4

- 7 a. A pair of gears 40 and 30 teeth respectively are of 25° involute form. Addendum = 5mm, Module = 2.5mm. If the smaller wheel is the driver and rotate at 1500rpm, find the velocity of sliding at the point of engagement, out pitch point and the point of disengagement, length of path of contact and length of Arc of contact. (10 Marks)
- b. Explain minimum of teeth on a Gear to avoid interference and minimum number of teeth on a pinion to avoid interference. (06 Marks)

OR

- 8 In an epicyclic gear train, the internal wheels A, B and compound wheel C and D rotate independently about the axis 'O'. The wheels E and F rotate on a pin fixed to the Arm G. E gears with A and C, and F gears with B and D. All the wheels have same pitch and the number of teeth on E and F are 18, C = 28, D = 26
- Sketch the arrangement
 - Find the number of teeth on A and B
 - If the Arm G makes 15rpm CW and A is fixed, find speed of B
 - If the Arm G makes 150rpm CW and wheel A makes 15rpm CCW, find speed of B.

(16 Marks)

Module-5

- 9 A cam rotating clockwise at uniform, speed of 300 rpm operates a reciprocating follower through a roller 1.5cm diameter. The follower motion is defined as below
- Outward during 150° with U.A.R.M
 - Dwell for next 30°
 - Return during next 120° with SHM
 - Dwell for the remaining period
- Stroke of the follower is 3 cm. Minimum radius of the cam is 3 cm. Draw the cam profile.
Follower axis passes through the cam axis. (16 Marks)

OR

- 10 A symmetrical tangent cam operating a roller follower has the following particulars Radius of base circle of cam = 40mm, Roller radius = 20mm, Angle of ascent = 75° , total lift = 20mm, N = 300rpm. Determine :
- Principle Dimensions of the cam
 - The equation of the displacement curve when follower is in contact with straight flank.
 - Acceleration of the follower, when it is in contact with the straight flank where it merges into circular nose. (16 Marks)

* * * * *

USN

--	--	--	--	--	--	--	--	--	--

Fourth Semester B.E. Degree Examination, Dec.2018/Jan.2019 Applied Thermodynamics

Time: 3 hrs.

Max. Marks: 80

Note: 1. Answer FIVE full questions, choosing one full question from each module.
2. Use of steam table/Mollier chart/Psychrometric chart is permitted.

Module-1

- 1 a. Derive an expression of Air-standard efficiency of otto cycle with neat sketch of P-V and T-S diagrams. (06 Marks)
- b. With a neat sketch, explain the working of Ram jet. (05 Marks)
- c. Calculate the percentage loss in the ideal efficiency of a diesel engine with compression ratio 14 if the fuel cut-off is delayed from 5% to 8%. (05 Marks)

OR

- 2 a. With a neat block diagram and T-S diagram, explain how 'regeneration' increases thermal efficiency of gas turbine plant. (06 Marks)
- b. Define Air-standard efficiency. (02 Marks)
- c. A Gas turbine unit has a pressure ratio 6 : 1 and maximum cycle temperature of 610°C. The isentropic efficiencies of the compressor and turbine are 0.80 and 0.82 respectively. Calculate the power output when the air enters the compressor at 15°C at the rate of 16 kg/s. Take $C_p = 1.005$ KJ/kgK and $\gamma = 1.4$ for compression and $C_p = 1.11$ kJ/kgK and $\gamma = 1.333$ for expansion processes. (08 Marks)

Module-2

- 3 a. With the help of corresponding flow and T-S diagrams explain briefly the working of a practice regenerative Rankine cycle with one open feed water heater. Derive also an expression for its thermal efficiency. (08 Marks)
- b. A simple Rankine cycle works between the boiler pressure of 3 MPa and condenser pressure of 4 KPa. The steam is dry saturated before the throttling in the turbine. Determine (i) Rankine cycle efficiency (ii) Work ratio (iii) Specific steam consumption. (08 Marks)

OR

- 4 a. Discuss the effect of, (i) Boiler pressure (ii) Condenser pressure (iii) Super heat on the performance of a Rankine cycle. (08 Marks)
- b. A steam power plant operates on a theoretical reheat cycle. Steam at boiler at 150 bar, 550°C expands through the high pressure turbine. It is reheated at a constant pressure of 40 bar to 550°C and expands through the low pressure turbine to a condenser at 0.1 bar. Draw h-s diagram. Find (i) Quality of steam at turbine exhaust (ii) Cycle efficiency (iii) Steam rate in $\frac{\text{kg}}{\text{hr.KW}}$ (08 Marks)

Module-3

- 5 a. Explain the following: (i) Stoichiometric air (ii) Enthalpy of formation. (04 Marks)
- b. Explain the method of finding friction power using Morse test. (04 Marks)
- c. A Solid fuel contains by weight, carbon 71%, hydrogen 4%, oxygen 9%, Sulphur 3%. Nitrogen 1% and the remainder is ash. Determine the minimum quantity of air required for complete combustion of 1 kg of fuel. If the actual air supplied is 1.3 times the minimum required for complete combustion, estimate the percentage gravimetric composition of dry gases. (08 Marks)

Important Note : 1. On completing your answers, compulsorily draw diagonal cross lines on the remaining blank pages.
2. Any revealing of identification, appeal to evaluator and /or equations written eg. 42+8 = 50, will be treated as malpractice.

OR

- 6 a. Classify the IC engines. (04 Marks)
 b. Define : (i) BSFC (ii) Indicated thermal efficiency. (04 Marks)
 c. In a trial of a single cylinder oil engine working on dual cycle, the following observations were made:
 Oil consumption = 10.2 kg/h ; Calorific value of fuel = 43890 kJ/kg
 Air consumption = 3.8 kg/min; Speed = 1900 rpm
 Torque on the brake drum = 186 N-m; Quantity of cooling water used = 15.5 kg/min
 Temperature rise = 36°C; Exhaust gas temperature = 410°C
 Room temperature = 20°C; 'C_p' of exhaust gases = 1.17 kJ/kgK
 Calculate Brake thermal efficiency and draw heat balance sheet on minute basis. (08 Marks)

Module-4

- 7 a. With a neat sketch, explain the working of Bell – Coleman air refrigeration cycle. (06 Marks)
 b. Show the following processes on psychometric chart: (i) Sensible heating and cooling (ii) Cooling and dehumidification (04 Marks)
 c. In a simple vapour compression cycle, following are the properties of the refrigerant R-12 at various points;
 Compressor inlet : $h_2 = 183.2$ KJ/kg; $V_2 = 0.0767$ m³/kg
 Compressor discharge : $h_3 = 222.6$ KJ/kg; $V_3 = 0.0164$ m³/kg
 Compressor exit : $h_4 = 84.9$ KJ/kg; $V_4 = 0.00083$ m³/kg
 The piston displacement volume for compressor is 1.5 litres per stroke and its volumetric efficiency is 80%. The speed of the compressor is 1600 rpm. Find (i) Power rating of the compressor (KW) (ii) Refrigerating effect (KW) (06 Marks)

OR

- 8 a. Define (i) Dry bulb temperature (ii) Wet bulb temperature (iii) Dew point temperature (iv) Relative humidity. (04 Marks)
 b. State the properties of good refrigerant. (04 Marks)
 c. An air conditioning system is designed under the following conditions:
 Outdoor conditions = 30°C DBT and 75% RH
 Required indoor conditions = 22°C DBT and 70% RH
 Amount of free air circulated = 3 m³/sec
 Coil dew point temperature = 14°C
 The required condition is achieved first by cooling and dehumidification and then by heating. Calculate (i) the capacity of the cooling coil in tones.
 (ii) the capacity of the heating coil in KW.
 (iii) the amount of water vapour removed in kg/s. (08 Marks)

Module-5

- 9 a. What are the advantages of multistage compression? (04 Marks)
 b. What do you mean by a supersaturated flow? Explain with the help of h-s diagram. (06 Marks)
 c. A single stage double-acting air compressor is required to deliver 14 m³ of air per minute at 1.013 bar and 15°C. The delivery pressure is 7 bar and the speed 300 rpm. Take the clearance volume as 5% of the swept volume with the compression and expansion index $n = 1.3$, calculate (i) Swept volume of cylinder (ii) Indicated power. (06 Marks)

OR

- 10 a. Derive an expression for the condition for minimum work input required for two stage compressor with perfect intercooling. (08 Marks)
 b. A multistage compressor is to be designed to elevate the pressure from 1 bar to 120 bar, such that the stage pressure ratio will not exceed 4. Determine (i) Number of stages (ii) Minimum power required (iii) Intermediate pressures (iv) Exact pressure ratio. It is required to compress 15 m³/min of free air. Take $n = 1.2$ (08 Marks)

* * * 2 of 2 * * *

USN

--	--	--	--	--	--	--	--	--	--

15ME44

Fourth Semester B.E. Degree Examination, Dec.2018/Jan.2019 Fluid Mechanics

Time: 3 hrs.

Max. Marks: 80

Note: Answer FIVE full questions, choosing one full question from each module.

Module-1

- 1 a. Define the following properties of fluids with their units:
 - (i) Weight density.
 - (ii) Dynamic viscosity.
 - (iii) Bulk modulus (06 Marks)
- b. An oil film of thickness 1.5 mm is used for lubrication between a square plate of size 0.9m × 0.9m slides down an inclined plane having an inclination of 20° with the horizontal. The weight of square plate is 392.4 N and it slides down the plane with a uniform velocity of 0.2 m/s. Find the kinematic viscosity of oil. specific gravity of the oil is 0.7 (05 Marks)
- c. A simple U-tube manometer containing mercury is connected to a pipe in which a fluid of Sp.gravity 0.8 and having vacuum pressure is flowing. The other end of manometer is open to atmosphere. Find the vacuum pressure in pipe, if difference of mercury level in two limbs is 40 cm and height of fluid in the left from the centre of pipe is 15 cm below. (05 Marks)

OR

- 2 a. State and prove Pascal's law. (06 Marks)
- b. Derive expression for total pressure and centre of pressure for a plane surface immersed vertically in a static mass of fluid. (06 Marks)
- c. A uniform body of size 3m long × 2m wide × 1 m deep floats in water. What is the weight of the body if depth of immersion is 0.8 m? Determine the meta centric height also. (04 Marks)

Module-2

- 3 a. Explain different types of fluid flow. (06 Marks)
- b. The stream function for a two dimensional flow is given by $\psi = 2xy$, calculate the velocity at the point P(2, 3). Find the velocity potential ϕ . (04 Marks)
- c. Obtain the Euler's equation of motion along a stream line and hence derive Bernoulli's equation for a steady incompressible fluid flow. State the assumptions made. (06 Marks)

OR

- 4 a. Derive an expression for discharge through a triangular notch. (05 Marks)
- b. A jet of water of diameter 50 mm having velocity 40 m/s, strikes a curved fixed symmetrical plate at its centre. The jet is deflected through an angle 120° at the outlet of the curved plate. Calculate the force exerted by jet of water in the direction of jet and perpendicular to jet. (05 Marks)
- c. Find the discharge of water flowing through a pipe 30 cm diameter placed in an inclined position where a venturimeter is inserted, having a throat diameter of 15 cm. The difference of pressure between the main and throat is measured by a liquid of specific gravity 0.6 in an inverted U-tube which gives a reading of 30 cm. The loss of head between the main and throat is 0.2 times the kinetic head of the pipe. (06 Marks)

Important Note : 1. On completing your answers, compulsorily draw diagonal cross lines on the remaining blank pages.
2. Any revealing of identification, appeal to evaluator and /or equations written eg. 42+8 = 50, will be treated as malpractice.

Module-3

- 5 a. Prove that the ratio of maximum velocity to average velocity for laminar flow between two stationary parallel plates is 1.5. (10 Marks)
- b. A fluid of viscosity 0.7 NS/m^2 and specific gravity 1.3 is flowing through a circular pipe of diameter 100 mm. The maximum shear stress at the pipe wall is given as 196.2 N/m^2 . Find (i) the pressure gradient (ii) Average velocity (iii) Reynold's number of the flow. (06 Marks)

OR

- 6 a. What are the energy losses that occur in pipes? Give the expressions for different minor energy losses. (04 Marks)
- b. An oil of specific gravity 0.9 and viscosity 0.06 poise is flowing through a pipe of diameter 200 mm at the rate of 60 lit/sec. Find the head lost due to friction for a 500 m length of pipe. Find the power required to maintain this flow. (06 Marks)
- c. Three pipes of lengths 800 m, 500 m and 400 m and of diameters 500 mm, 400 mm and 300 mm respectively are connected in series. These pipes are replaced by a single pipe of 1700 m. Find the diameter of single pipe. (06 Marks)

Module-4

- 7 a. Define the terms:
 (i) Boundary layer thickness.
 (ii) Energy thickness
 (iii) Lift
 (iv) Drag (04 Marks)
- b. Write a short note on boundary layer separation and methods to control it. (06 Marks)
- c. A long plate of size $5\text{m} \times 2\text{m}$ is moving in air with velocity of 9 km/hr parallel to its length. Calculate the drag force on both sides of plate if, (i) Boundary layer is laminar over the complete plate. (ii) Boundary layer is turbulent over the complete plate.
 Take $\rho_{\text{air}} = 1.2 \text{ kg/m}^3$ and $\mu = 1.8 \times 10^{-4}$ poise (06 Marks)

OR

- 8 a. The pressure difference Δp in a pipe of diameter D and length l due to viscous flow depends on the velocity V , viscosity μ and density ρ . Using Buckingham's π -theorem. Obtain an expression for Δp . (10 Marks)
- b. Explain (i) Geometric similarity (ii) Kinematic similarity (iii) Dynamic similarity (06 Marks)

Module-5

- 9 a. Define stagnation properties. Obtain an expression for stagnation pressure of a compressible fluid in terms of Mach number and pressure. (10 Marks)
- b. A projectile travels in air of pressure 15 N/cm^2 at 10°C at a speed of 1500 km/hr. Find the Mach number and Mach angle. Assume $\gamma = 1.4$ and $R = 287 \text{ J/kgK}$. (04 Marks)
- c. What are normal and oblique shocks? (02 Marks)

OR

- 10 a. Show that velocity of propagation of elastic wave in an adiabatic medium is given by $C = \sqrt{\gamma RT}$ starting from fundamentals. (08 Marks)
- b. Calculate the stagnation temperature on nose of plane which is flying at 800 km/hr through still air having a pressure 8 N/cm^2 and temperature -10°C . Take $R = 287 \text{ J/kgK}$ and $\gamma = 1.4$ (02 Marks)
- c. Define computational fluid dynamics. Mention the applications of CFD. (06 Marks)

* * * * *

USN

--	--	--	--	--	--	--	--	--	--

15MEA405

Fourth Semester B.E. Degree Examination, Dec.2018/Jan.2019
Metal Casting and Welding

Time: 3 hrs.

Max. Marks: 80

Note: Answer any FIVE full questions, choosing one full question from each module.

Module-1

- 1 a. Explain the steps involved in making a sand casting. (06 Marks)
b. Explain with neat sketches the various steps involved in shell moulding. (10 Marks)

OR

- 2 a. Explain the various allowances provided on the pattern. (08 Marks)
b. Explain with neat sketches, the open riser blind riser. (08 Marks)

Module-2

- 3 a. Explain with a neat sketch, the working principle of direct arc electric furnace. (08 Marks)
b. Explain with a neat sketch, the continuous casting process. (08 Marks)

OR

- 4 a. Explain with a neat sketch, the working of Cupola. (10 Marks)
b. Explain with a neat sketch, the true centrifugal casting process. (06 Marks)

Module-3

- 5 a. Explain with neat sketches, any two types of vacuum degasification methods. (08 Marks)
b. Discuss the advantages and limitations of Aluminium castings. (08 Marks)

OR

- 6 a. Explain with neat sketches, different types of defects that occur during casting. (08 Marks)
b. Explain with a neat sketch, the working principle of Stir casting process. (08 Marks)

Module-4

- 7 a. Explain with a neat sketch, metal inert gas welding process. (08 Marks)
b. Explain with a neat sketch, projection welding process and mention its advantages and limitations. (08 Marks)

OR

- 8 a. Explain with a neat sketch, atomic hydrogen welding process. (08 Marks)
b. Explain laser beam welding process with a neat sketch. Mention its advantages. (08 Marks)

Module-5

- 9 a. Explain different zones of welded joint with a neat sketch. (06 Marks)
b. Explain with a neat sketch, holography inspection method. Mention its advantages and limitations. (10 Marks)

OR

- 10 a. Define soldering and brazing. Mention the advantages and limitations of soldering and brazing process. (08 Marks)
b. Explain with neat sketches, fluorescent penetrant inspection method. (08 Marks)

* * * * *

Important Note : 1. On completing your answers, compulsorily draw diagonal cross lines on the remaining blank pages.
2. Any revealing of identification, appeal to evaluator and /or equations written eg. 42+8 = 50, will be treated as malpractice.

CBCS SCHEME

USN

--	--	--	--	--	--	--	--	--	--

15ME46B

Fourth Semester B.E. Degree Examination, Dec.2018/Jan.2019 Mechanical Measurements and Metrology

Time: 3 hrs.

Max. Marks: 80

Note: Answer any FIVE full questions, choosing one full question from each module.

Module-1

- 1 a. Explain the characteristics of line and end standards. (05 Marks)
b. With a neat sketch, explain Imperial Standard Yard. (05 Marks)
c. Four length bars of basic length 100mm are to be calibrated using a calibrated length bar of 400mm, whose actual length is 399.9992mm. It was also found that length of bars B, C, D in comparison to A are + 0.0002, + 0.0004 and - 0.0001mm respectively and the length of all four bars put together in comparison to standard calibrated bar is + 0.0003mm longer. Determine the actual dimensions of all the four end bars. (06 Marks)

OR

- 2 a. Explain with a neat sketch, Wringing phenomenon of slip gauges. (08 Marks)
b. With a neat sketch, explain the uses of sine bar. (08 Marks)

Module-2

- 3 a. Explain with a neat sketch, different types of fits. (08 Marks)
b. Explain briefly Selective assembly and Interchangeability. (08 Marks)

OR

- 4 a. With a neat sketch, explain plug gauges and snap gauges. (10 Marks)
b. With a neat sketch, describe the construction and working of Johansson - Mikro Kator. (06 Marks)

Module-3

- 5 a. Explain the 3 - wire method of finding effective diameter of screw threads. (08 Marks)
b. With a sketch, define the following terms with respect to a screw thread i) Major diameter ii) Effective diameter iii) Pitch iv) Angle of thread. (08 Marks)

OR

- 6 a. Explain with a neat sketch, 'Tool Maker's microscope. (08 Marks)
b. With a neat sketch, explain laser interferometer. (08 Marks)

Module-4

- 7 a. Briefly explain the generalized measurement system, with block diagram. (08 Marks)
b. List and explain the different types of errors. (08 Marks)

OR

- 8 a. Explain the inherent problems present in mechanical modifying system. (08 Marks)
b. Explain the working of "Cathode Ray Oscilloscope". (08 Marks)

Module-5

- 9 a. Explain briefly i) Proving ring ii) Prony brake dynamometer. (08 Marks)
b. Explain with neat sketch, the working of Bridgmann gauge. (08 Marks)

OR

- 10 a. Explain the wheat stone bridge arrangement for strain measurement. (08 Marks)
b. What is Thermocouple? State and explain the laws of thermo couple. (08 Marks)

* * * * *

Important Note : 1. On completing your answers, compulsorily draw diagonal cross lines on the remaining blank pages.
2. Any revealing of identification, appeal to evaluator and/or equations written eg. 42+8 = 50, will be treated as malpractice.