

**Model Question Paper-I/II with effect from 2021 (CBCS Scheme)**

USN

--	--	--	--	--	--	--	--	--	--

**First/Second Semester BE Degree Examination  
Engineering Visualization 21EVL15/25**

TIME: 03 Hours

Max. Marks: 100

- Note: 01. Answer all **FOUR** full questions  
02. Grid sheets may be provided for making preparatory sketches

		<b>Module -1</b>	<b>Marks</b>
Q.01	(a)	A point 20 mm above XY-line is the front view of two points E and F. The top view of E is 35 mm behind VP, and the top view of F is 40 mm in-front of VP. Draw the projections of two points and state their positions with reference planes and the quadrants in which they lie.	08
	(b)	The end A of a line AB is in HP and 25 mm in-front of VP. The end B is in VP and 50 mm above HP. The distance between the end projectors when measured parallel to the line of intersection of HP and VP is 65 mm. Draw the projections of the line AB and determine its true length and true inclinations with HP & VP.	12
		<b>Module-2</b>	
Q.02		A pentagonal prism of 30 mm side of base and height 70 mm rests with a corner of the base on HP such that an edge of the base containing the corner on which the prism rests is inclined at 40° to HP, the axis of the prism is inclined at 30° to HP and 45° to VP. Draw the top and front views of the prism.	30
		<b>Module-3</b>	
Q.03		Using first angle projection, draw front view looking in the direction of X, top view and right side view of the machine component as shown in Figure Q3.1	25
		<b>Module-4</b>	
Q.04		Draw the development of the tray whose top-view and front-view are as shown in Figure Q4.1	25
		<p align="center"><b>Figure Q3.1</b></p>	
		<p align="center"><b>Figure Q4.1</b></p>	

Problem 1a)

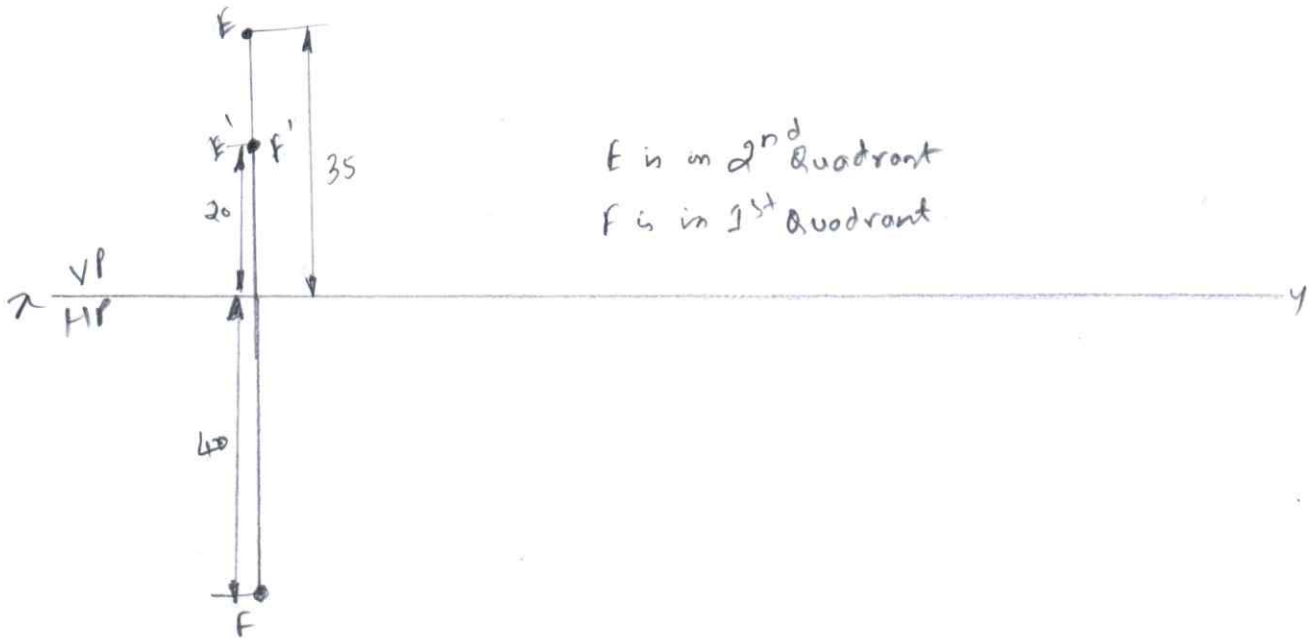

Problem 1b)

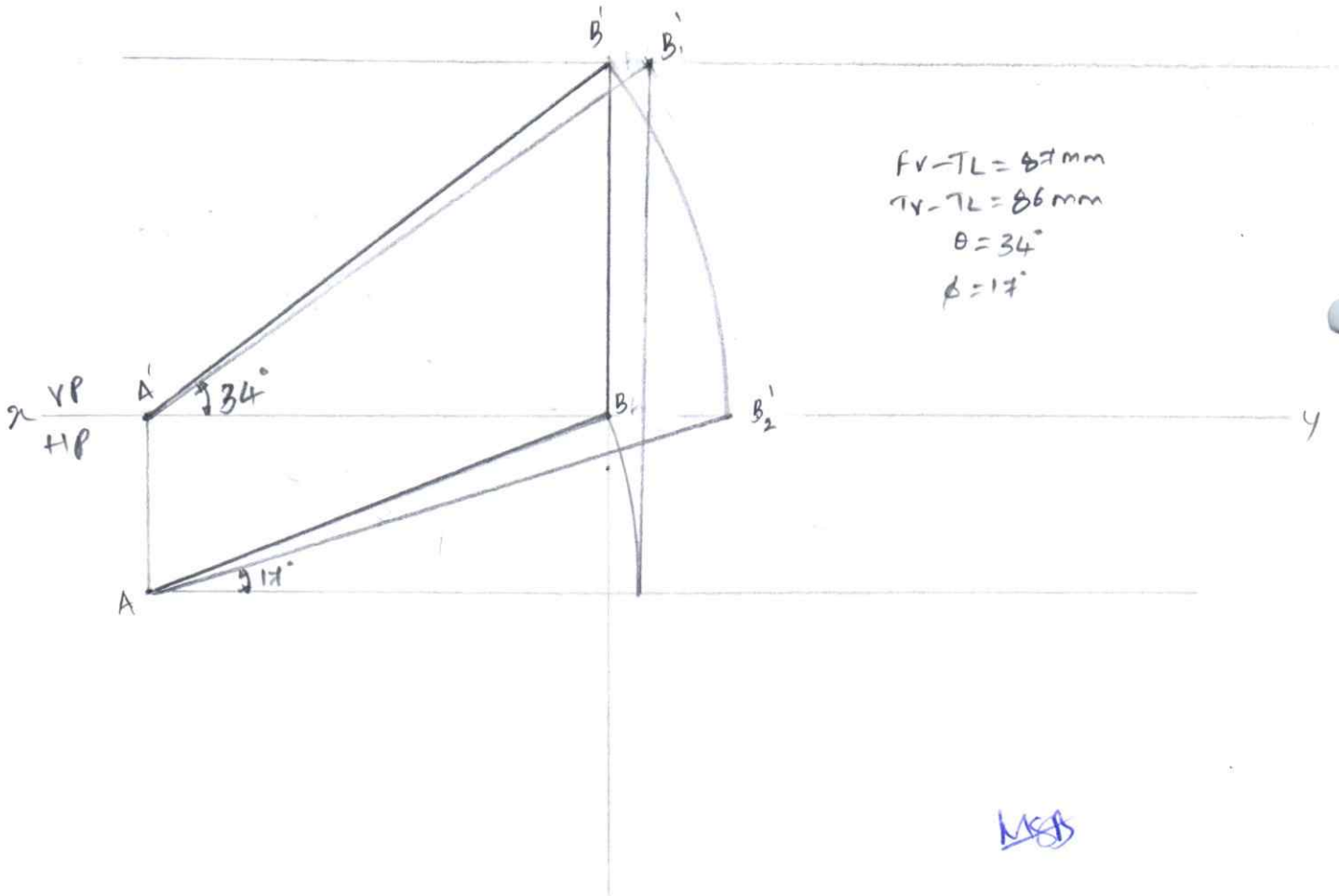

Problem 2

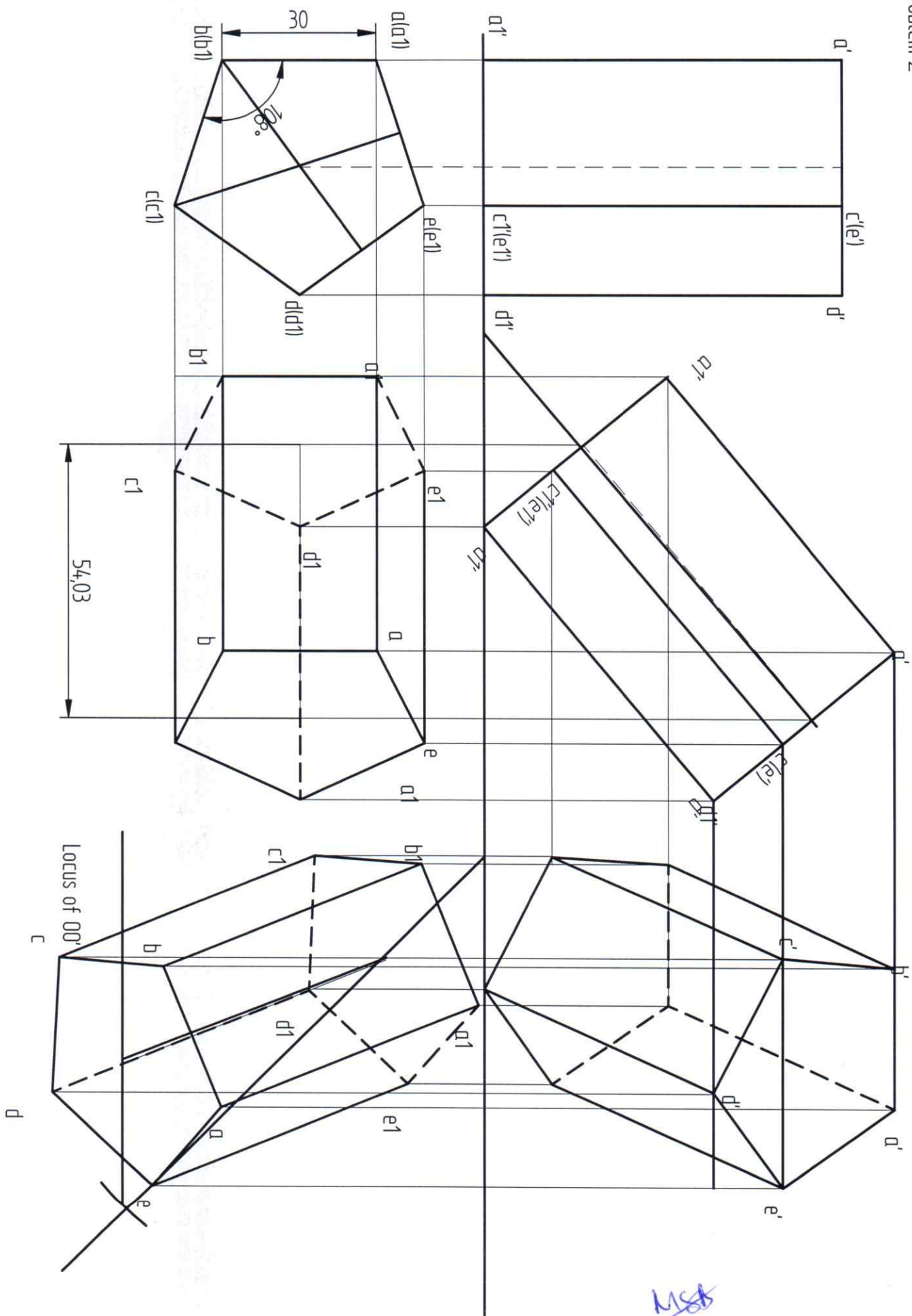

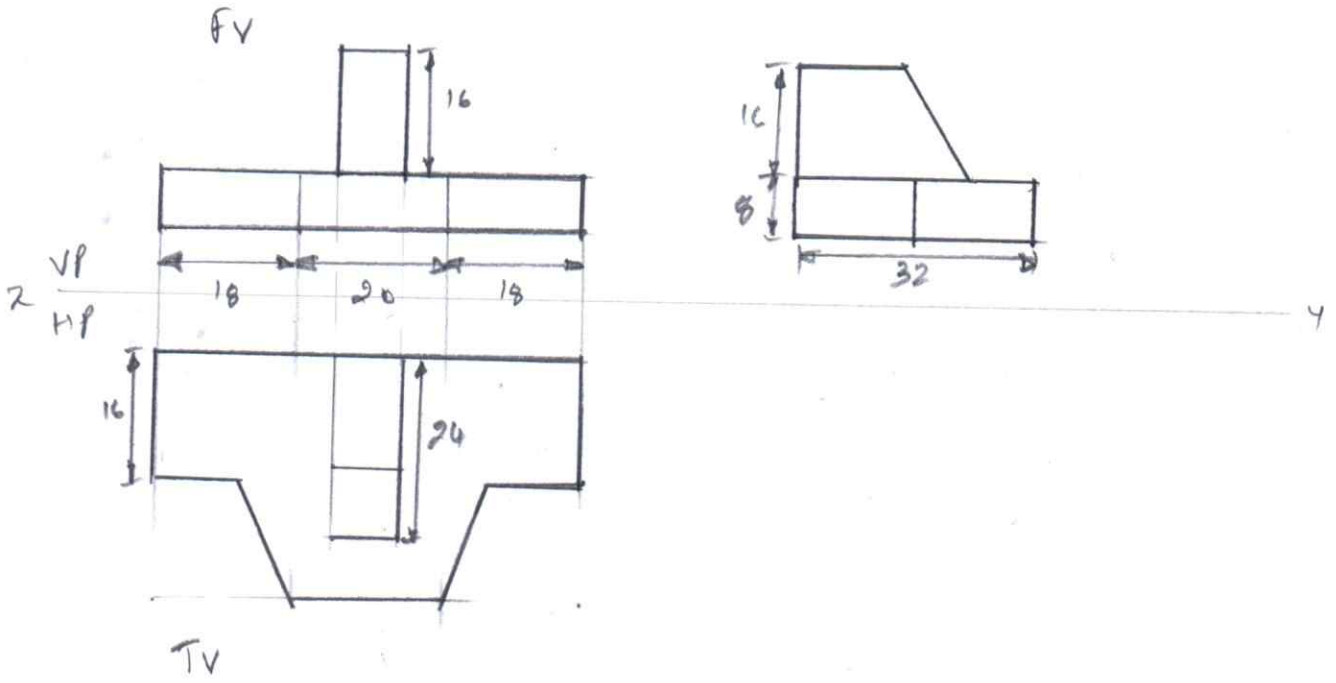

Problem 3

LSV

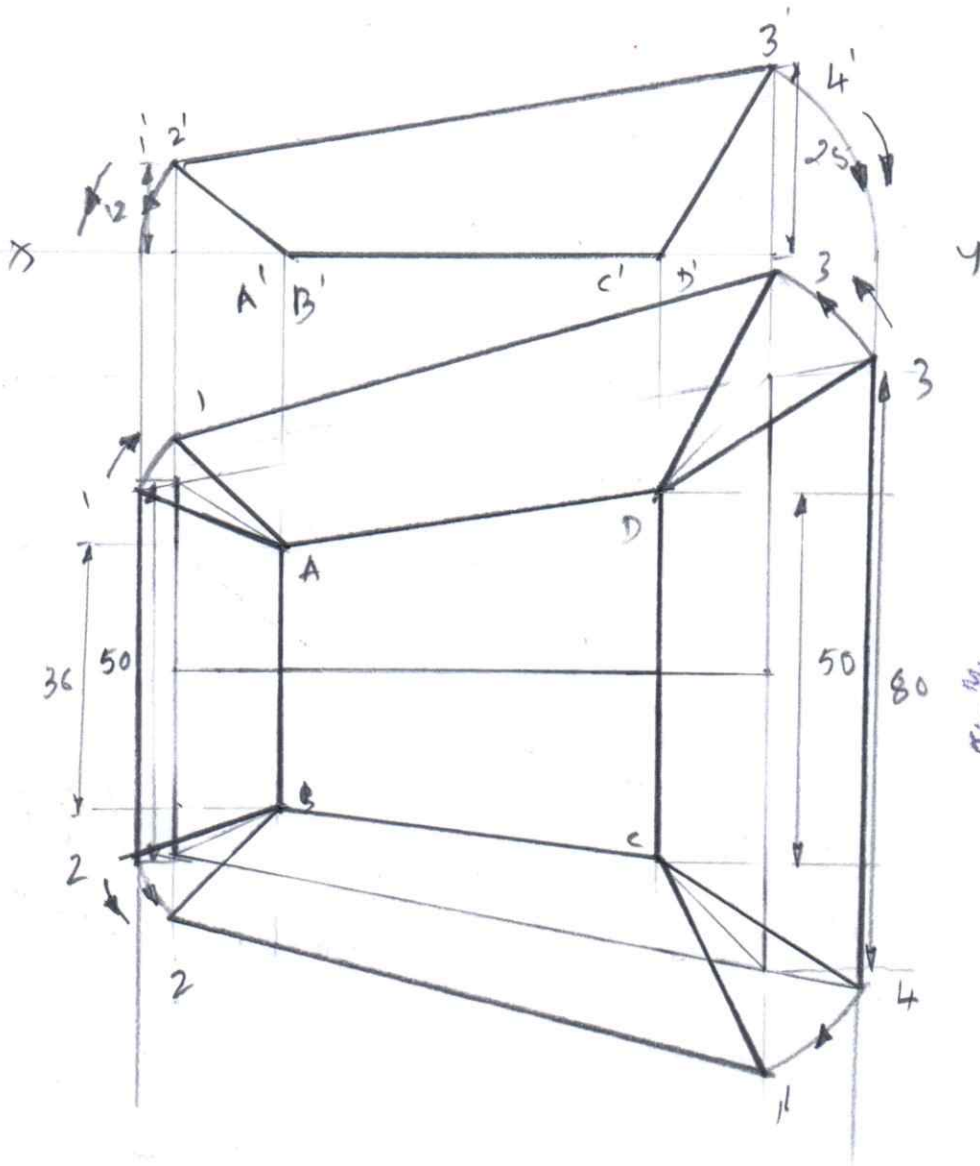

Problem 4



  
 MOD.  
 Mechanical Engineering  
 vishwanathrao Deshpande  
 Institute of Technology  
 Mallayal-5d1 328

MISA